

PMI.PMP.v2023-07-10.q276

Exam Code:	PMP
Exam Name:	Project Management Professional (2025 Version)
Certification Provider:	PMI
Free Question Number:	276
Version:	v2023-07-10
# of views:	8326
# of Questions views:	2760
https://www.exam-tests.com/PMP-exam/PMI.PMP.v2023-07-10.q276.html	

NEW QUESTION: 1

Which process involves aggregating the estimated costs of the individual schedule activities or work packages?

- A. Cost baseline
- B. Cost forecasting
- C. Cost variance
- D. Cost budgeting

Answer: D (LEAVE A REPLY)

Section: Monitoring and Controlling

NEW QUESTION: 2

A project manager who allows the team to make the majority of the decisions is demonstrating a(n) _____ leadership style.

- A. Demographic
- B. Boss-centered
- C. Autocratic
- D. Laissez-faire
- E. Subordinate centered

Answer: E (LEAVE A REPLY)

NEW QUESTION: 3

A project manager has just completed a fixed-price project and the stakeholder is unhappy with the result. What should the project manager do?

- A. Explain to the stakeholder that any modifications require additional budget
- B. Speak with the team's manager to get extra hours from the team
- C. Review the project charter for the project approval criteria
- D. Review the missed program deliverables with the project team

Answer: C ([LEAVE A REPLY](#))

NEW QUESTION: 4

Who, along with the project manager, is supposed to direct the performance of the planned project activities and manage the various technical and organizational interfaces that exist within the project?

- A. The sponsors and stakeholders
- B. The risk owners and stakeholders
- C. The customer and functional managers
- D. The project management team

Answer: D ([LEAVE A REPLY](#))

NEW QUESTION: 5

Each project can benefit from stakeholder involvement; however, it is in both the project manager's and the teams' best interest to ensure that all project stakeholders have positive attitudes toward the project and its goals and objectives. Working as a project manager, you have a number of key stakeholders on your project. The stakeholder that identifies potential conflicts between organizational strategies and project goals is the_____

- A. Chairperson of the Governance Board
- B. Program manager
- C. Director of the project management office
- D. Chief Operating Officer

Answer: B ([LEAVE A REPLY](#))

Section: Mix Questions

Explanation:

Organizational strategy provides guidance and direction to project management. Portfolio managers, sponsors, or program managers identify alignment or potential conflicts between organizational strategies and project goals and communicates them to the project manager.

NEW QUESTION: 6

Which of the following tools and techniques of the Select Sellers process is used to check proposed pricing?

- A. Screening systems
- B. Independent estimates
- C. Proposal evaluation technique
- D. Seller rating systems

Answer: ([SHOW ANSWER](#))

Independent estimates, also called should cost estimates, are a way to check proposed pricing.

NEW QUESTION: 7

A strengths, weaknesses, opportunities, and threats (SWOT) analysis is a tool or technique used in which process?

- A. Identify Risks
- B. Control Risks
- C. Perform Quantitative Risk Analysis
- D. Perform Qualitative Risk Analysis

Answer: A ([LEAVE A REPLY](#))

NEW QUESTION: 8

The critical path in a schedule network is the path that:

- A. All of the other alternatives apply.
- B. Allows some flexibility in scheduling a start time.
- C. Takes the longest time to complete
- D. Must be done before any other tasks
- E. Is not affected by schedule slippage

Answer: C ([LEAVE A REPLY](#))

NEW QUESTION: 9

Recently your company introduced a new set of "metal woods" to its established line of golfing equipment.

However, in the past weeks many of the clubs have been returned because of quality problems. You decide to conduct a failure mode and criticality analysis to_____

- A. Analyze the product development cycle after product release to determine strengths and weaknesses
- B. Evaluate failure modes and causes associated with the design and manufacture of this product
- C. Evaluate failure modes and causes associated with the design and manufacture of a new product to replace the clubs
- D. Help management set priorities in its existing manufacturing processes to avoid failures

Answer: ([SHOW ANSWER](#))

Explanation/Reference:

Explanation:

This technique is a method of analyzing design reliability. A list of potential failure modes is developed for each element, and then each mode is given a numeric rating for frequency of occurrence, criticality, and probability of detection. These data are used to assign a risk priority number for prioritizing problems and guiding the design effort.

NEW QUESTION: 10

Which tools or techniques will a project manager use for Develop Project Team?

- A. Roles and responsibilities
- B. Prizing and promoting
- C. Recognition and rewards

D. Negotiation

Answer: C ([LEAVE A REPLY](#))

NEW QUESTION: 11

Which of the following statements about fast-tracking is TRUE?

A. None of the statements are true

B. One of the advantages of fast-tracking is that it can often lead to reduced rework and reduces project risks

C. Fast tracking is the process of increasing the schedule by overlapping various project tasks

D. Fast tracking refers to assigning additional resources to a project in an attempt to decrease project schedule/ timeline

E. Fast tracking involves performing activities sequentially

Answer: A ([LEAVE A REPLY](#))

NEW QUESTION: 12

All the following statements relating to communication management are correct EXCEPT:

A. Communicating is the most critical skill that a project manager should possess

B. Communication Planning involves determining the information and communication needs of the stakeholders

C. Project Managers spend as more than 85% of their time communicating

D. To be effective, a Project Manager should control all communications

Answer: D ([LEAVE A REPLY](#))

NEW QUESTION: 13

The purpose of the project charter is:

A. To recognize the existence of the project, and commit organizational resources to the project-

B. To acknowledge the existence of the project team, project manager, and project sponsor.

C. To recognize and acknowledge the project sponsor.

D. To describe the selection method used to choose the project

Answer: ([SHOW ANSWER](#))

NEW QUESTION: 14

A project manager must obtain approval for a network cabling project. After preparation of detailed information, some team members remain dissatisfied, as the selected equipment is new and insufficiently tested. The project manager determines that the equipment meets technology needs.

What skills should the project manager use to obtain team consensus and sponsor approval?

A. Interpersonal

B. Team-building

C. Stakeholder engagement

D. Leadership

Answer: (SHOW ANSWER)

Section: Initiation

NEW QUESTION: 15

Which of the following Scope Management process involves breaking down a project into smaller manageable units?

- A. Initiation
- B. Scope Verification
- C. Scope Planning
- D. Scope Definition

Answer: D (LEAVE A REPLY)

NEW QUESTION: 16

Which of the following statements about the cost of quality are true?

- A. Both 1) the cost of quality is the expense of nonconformance to requirements and specifications and 2) quality control programs should be implemented when the cost of quality are deemed affordable by management.
- B. quality control programs should be implemented when the cost of quality are deemed affordable by management.
- C. Both 1) the cost of quality is the expense of nonconformance to requirements and specifications and 2) the cost of quality are mostly the direct responsibility of workers who are manufacturing the product.
- D. the cost of quality are mostly the direct responsibility of workers who are manufacturing the product.
- E. the cost of quality is the expense of nonconformance to requirements and specifications.

Answer: E (LEAVE A REPLY)

Valid PMP Dumps shared by BraindumpsPass.com for Helping Passing PMP Exam!

BraindumpsPass.com now offer the **newest PMP exam dumps**, the BraindumpsPass.com PMP exam **questions have been updated** and **answers have been corrected** get the **newest** BraindumpsPass.com PMP dumps with Test Engine here:

<https://www.braindumpsPass.com/PMI/PMP-practice-exam-dumps.html> (1440 Q&As Dumps,

40%OFF Special Discount: Exam-Tests)

NEW QUESTION: 17

Your customer signed off on the requirements document and scope statement of your video game project last month. Today she stated she would like to make it an interactive game that can be played on a television and on a computer. This represents a requested scope change that, at a minimum _____

- A. Should be reviewed according to the perform integrated change control process
- B. Results in a change to all project baselines
- C. Requires adjustments to cost, time, quality, and other objectives
- D. Results in a lesson learned

Answer: A ([LEAVE A REPLY](#))

Section: Mix Questions

Explanation:

A requested change is an output from the control scope process. Such a change should be handled according to the integrated change control process and may result in an update to the scope baseline or other components of the project management plan.

NEW QUESTION: 18

Which input will be used when tasked with developing the human resource plan?

- A. Activity resource requirements
- B. Project management plan
- C. Project staff assignments
- D. Resource calendar

Answer: ([SHOW ANSWER](#))

NEW QUESTION: 19

A key project stakeholder and influencer has suddenly withdrawn their sponsorship and is now actively opposing the project. What should the project manager do to address this situation?

- A. Request a meeting with the stakeholder to discuss the project and try to mitigate any misunderstandings and miscommunications.
- B. Research the stakeholder's background to understand if the opposition is based upon a previous issue.
- C. Update the stakeholder register with the assessment and classification that the stakeholder is no longer supporting the project.
- D. Report the stakeholder to the project sponsor as a threat and ask the sponsor to speak with the stakeholder.

Answer: A ([LEAVE A REPLY](#))

Section: Monitoring and Controlling

Explanation/Reference:

NEW QUESTION: 20

Your project's primary constraint is quality. To make certain the project team members don't feel too pressed for time and to avoid schedule risk, which of the following tools does not take into consideration risks when estimating the duration of project activities?

- A. Analogous estimating
- B. Triangular
- C. Bottom-up estimating

D. Beta

Answer: A ([LEAVE A REPLY](#))

NEW QUESTION: 21

Which of the following procurement processes results in the awarding of a procurement contract?

- A. Administer Procurements
- B. Conduct Procurements
- C. Plan Procurements
- D. Close Procurements

Answer: B ([LEAVE A REPLY](#))

NEW QUESTION: 22

Life cycle costing:

- A. B and C
- B. Does not take into consideration the effect of project decisions on the cost of using the resulting product.
- C. Includes acquisition, operating, and disposal costs when evaluating various alternatives.
- D. Includes only the cost of the development or acquisition of a product or service.

Answer: C ([LEAVE A REPLY](#))

NEW QUESTION: 23

Which equation correctly illustrates the cost variance of a project, in dollars?

- A. $BCWP - BCWS$
- B. $BCWP / ACWP$
- C. $BCWP / BCWS$
- D. $BCWP - ACWP$

Answer: ([SHOW ANSWER](#))

NEW QUESTION: 24

A team is experiencing difficulties and has decided to use a spike. Please click on the portion of the burndown chart that corresponds to the spike.



Answer:

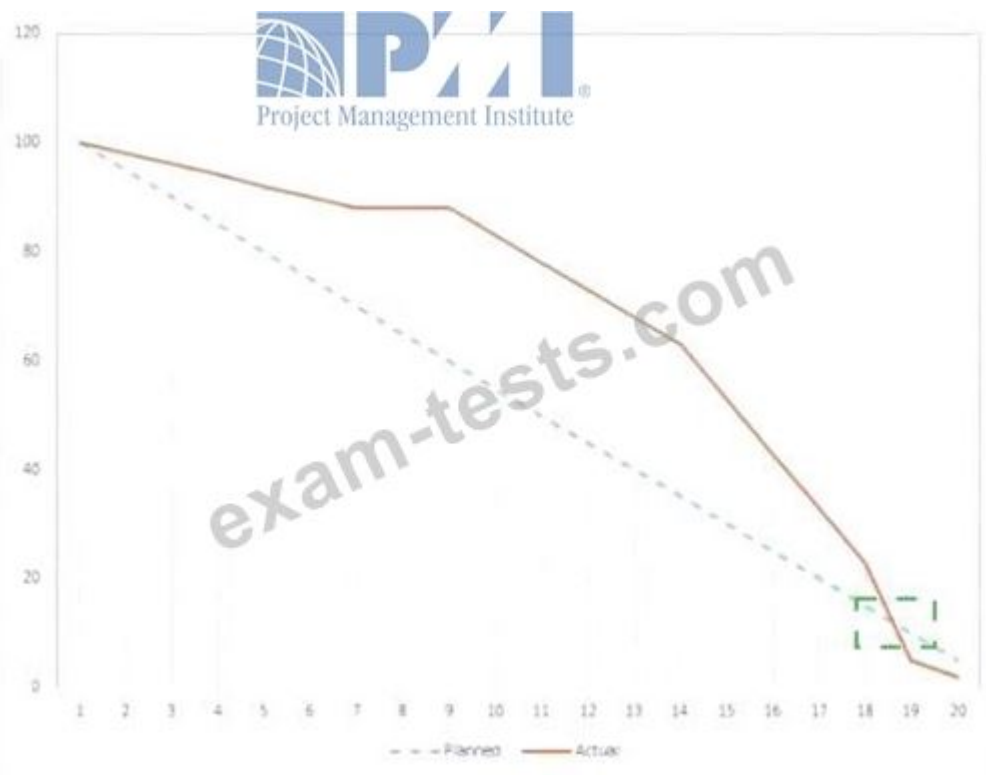

NEW QUESTION: 25

Please refer to the chart given below:

Task	Preceding Activity	Estimate Mont
Start	-	0
1	Start	3
2	1	4
3	Start	2
5	3	5
4	Start	7
5	4	1
End	2	3
End	5	4

What is the length of the critical path?

- A. 14
- B. 11
- C. 10

D. 12

Answer: D ([LEAVE A REPLY](#))

NEW QUESTION: 26

You are the project manager for a construction company that is building a new city and county office building in your city. Your CCB recently approved a scope change. You know that scope change might come about as a result of all of the following except which one?

- A. Product scope change
- B. Changes to the project requirements
- C. Schedule revisions
- D. Changes to the agreed-upon WBS

Answer: ([SHOW ANSWER](#))

Scope changes will cause schedule revisions, but schedule revisions do not change the project scope. Project requirements are part of the project scope statement, and therefore D is one of the correct responses.

NEW QUESTION: 27

Constant bickering, absenteeism, and substandard performance have characterized the behavior of certain members of your team. You have planned an off-site retreat for the team to engage in a variety of activities. Your primary objective for investing time and money in this event is to improve_____

- A. Team performance
- B. Morale
- C. Quality
- D. Individual performance

Answer: ([SHOW ANSWER](#))

Explanation/Reference:

Explanation:

Team development leads to improved team performance, which ultimately results in improved project performance. Improvements in team performance can come from many sources and can affect many areas of project performance. For example, improved individual skill levels such as enhanced technical competence may enable team members to perform their assigned activities more effectively. Team development efforts have greater benefit when conducted early but should take place throughout the project life cycle.

NEW QUESTION: 28

A key stakeholder is concerned about a critical risk that may cause the project to run over budget. The project manager wants to share the mitigation plan with the stakeholder.

What should the project manager do first?

- A. Consult the communications management plan to identify how to inform the stakeholder
- B. Identify which deliverable in the work breakdown structure (WBS) will be affected by the risk

- C. Review the risk register to identify the mitigation plan.
- D. Check the organizational chart to determine the stakeholder's department.

Answer: ([SHOW ANSWER](#))

NEW QUESTION: 29

A vendor informed the project manager that a critical resource will be on a long leave of absence. The project team reviewed the pending vendor deliverables and identified an alternative solution, but the solution will incur an additional cost. The project is currently on schedule and slightly under budget. What should the project manager do next?

- A. Perform Integrated Change Control
- B. Request a replacement resource
- C. Perform a cost-benefit analysis
- D. Implement risk responses

Answer: ([SHOW ANSWER](#))

NEW QUESTION: 30

Constrained optimization models and benefit measurement method are examples of:

- A. Types of scope definition methods.
- B. Project selection methods
- C. Types of cost measurement methods.
- D. Activity selection methods.

Answer: B ([LEAVE A REPLY](#))

There are two broad categories of project selection.

< li >The first is the benefit measurement method.

This method measures the potential benefits of executing the project against the potential benefits of other projects put before the organization.

< li >A second type of selection method is termed "constrained optimization models."

These types of models are in use only in certain types of projects and are not going to be used for simpler projects.

NEW QUESTION: 31

Which type of managers do composite organizations involve?

- A. Functional managers and manager of project managers
- B. Functional managers only
- C. Project managers only
- D. Technical managers and project managers

Answer: A ([LEAVE A REPLY](#))

Section: Initiation

Valid PMP Dumps shared by BraindumpsPass.com for Helping Passing PMP Exam!
BraindumpsPass.com now offer the **newest PMP exam dumps**, the BraindumpsPass.com PMP exam **questions have been updated** and **answers have been corrected** get the **newest** BraindumpsPass.com PMP dumps with Test Engine here:
<https://www.braindumpsPASS.com/PMI/PMP-practice-exam-dumps.html> (1440 Q&As Dumps, **40%OFF Special Discount: Exam-Tests**)

NEW QUESTION: 32

"Tailoring" is defined as the:

- A. effort of addressing each process to determine which are appropriate and their appropriate degree of rigor.
- B. act of creating a project team with the specialized skills required to produce a required product or service.
- C. action taken to bring a defective or nonconforming component into compliance with requirements or specifications.
- D. adjustment of the respective influences of time, cost, and quality in order to most efficiently achieve scope.

Answer: A (LEAVE A REPLY)

NEW QUESTION: 33

During risk analysis for a building renovation project, it is discovered that the building contains toxic materials that must be removed. What should the project manager do to mitigate this risk using the risk transference strategy?

- A. Increase the management reserves to address the potential impact of additional time and cost.
- B. Ask the client to remove the toxic materials and exclude this work from the contract.
- C. Train personnel how to remove the toxic materials and then perform the work.
- D. Hire a contractor to perform the work.

Answer: D (LEAVE A REPLY)

Section: Executing

NEW QUESTION: 34

Recommended corrective actions are an input to which process?

- A. Scope verification
- B. Direct and manage project execution
- C. Schedule development
- D. Scope control
- E. Integrate change control

Answer: E (LEAVE A REPLY)

NEW QUESTION: 35

You are interviewing new project managers for your company. One of the candidates claims to be a PMP-certified project manager, but you discover that she has never taken the PMP exam. What is the BEST way to handle this situation?

- A. Do nothing
- B. Report the person to PMI
- C. Call the police
- D. Report the person to your manager

Answer: B ([LEAVE A REPLY](#))

If you discover that someone claims to have the PMP credential but is not actually certified, you must contact PMI immediately so that they can take action.

NEW QUESTION: 36

In schedule development, mathematical analysis often produces a preliminary early-start schedule that shows peaks and valleys in the resource requirements. Resource Leveling done to take care of this issue may result in all the following except:

- A. Utilization of weekends, extended hours or multiple shifts
- B. Productivity increases by using different technologies and/or methodologies
- C. Reduction in project cost
- D. Increase in project duration

Answer: C ([LEAVE A REPLY](#))

NEW QUESTION: 37

Situational leadership as defined by Hersey and Blanchard consists of the stages

- A. Direct style, instrumental style, relational style.
- B. Acquisition stage, learning stage, performance stage, exhaustion stage
- C. Directing, supporting, coaching, delegating.
- D. Must-be requirements, one-dimensional requirements, attractive requirements

Answer: C ([LEAVE A REPLY](#))

NEW QUESTION: 38

Definitions of probability and impact, revised stakeholder tolerances, and tracking are components of which subsidiary plan?

- A. Communications management plan
- B. Cost management plan
- C. Risk management plan
- D. Quality management plan

Answer: ([SHOW ANSWER](#))

NEW QUESTION: 39

Reserve Analysis a technique not used in:

- A. Estimate Costs

- B. Estimating Activity Duration
- C. Control Costs
- D. Determine Budget

Answer: C (LEAVE A REPLY)

Reserve Analysis: Many cost estimators include reserves, also called contingency allowances, as costs in many schedule activity cost estimates. Reserve Analysis a technique not used in Control Costs.

NEW QUESTION: 40

Drag the organizational characteristics on the left to the correct scenario on the right

Organizational Characteristic	Scenario
Roadblock to achieving changes	Organization's willingness to shift the way it views, reviews, and assesses employees
Appetite for change by leading by example	Work is decomposed into department silos, creating dependencies that prevent accelerated delivery
Change tolerant	Decomposing work into iterative prototypes involves rework and needs change management techniques to address the hurdle of transitioning to agile
Change associated with agile	The scrum master tries to use agile techniques and practices wherever possible

Answer:

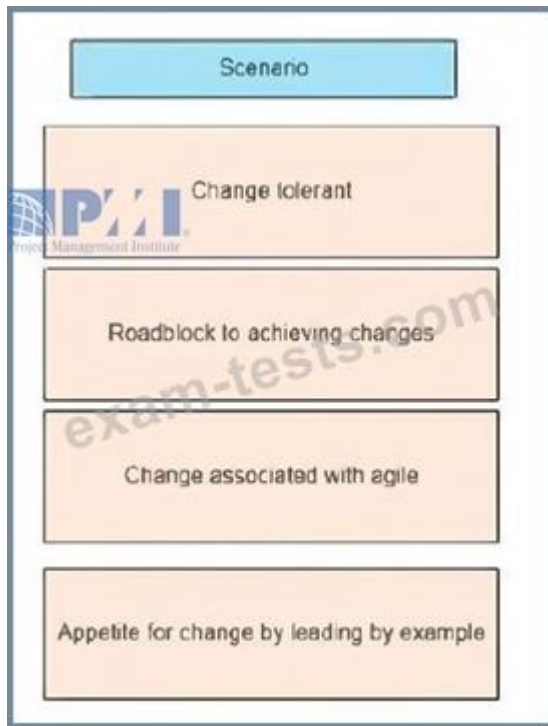

NEW QUESTION: 41

Risk Management Plan may include:

- A. Risk Response Audits, Earned Value Analysis, Technical Performance Measurement
- B. Risks, Triggers, Inputs to other processes
- C. Budgeting, Timing, Thresholds, Methodology
- D. Avoided, Transferred, Mitigated and Accepted Risks

Answer: C (LEAVE A REPLY)

NEW QUESTION: 42

Project managers should pay attention to critical and subcritical activities when evaluating project time performance. One way to do this is to analyze 10 sub critical paths in order of ascending float. This approach is part of _____

- A. Variance analysis
- B. Simulation
- C. Earned value management
- D. Trend analysis

Answer: A (LEAVE A REPLY)

Section: Mix Questions

Explanation:

Performance of variance analysis during the schedule monitoring process is a key element of time control.

Float variance is an essential planning component for evaluating project time performance.

NEW QUESTION: 43

Schedule milestones and a predefined budget are examples of:

- A. Project constraints.
- B. Requirements documentation.
- C. Organizational process assets.
- D. Activity cost estimates.

Answer: (SHOW ANSWER)

Section: Monitoring and Controlling

NEW QUESTION: 44

Which term is NOT a common name for a procurement document that solicits an offer from prospective sellers?

- A. Contractor initial response
- B. Request for information
- C. Request for quotation
- D. Invitation for negotiation

Answer: B (LEAVE A REPLY)

Explanation/Reference:

Explanation:

Procurement documents are used to solicit proposals from prospective sellers. A request for information is generally used by the buyer to have potential sellers propose various pieces of information related to a product, service, or result or to a seller capability.

NEW QUESTION: 45

The design engineer on the project team makes minor additions during the design process. These changes were added to the contract by procurement. These changes were not known to the project manager until implementation began. The project cost will increase marginally because of these changes.

What should the project manager do immediately?

- A. Terminate the contract, and restart the entire design process to mitigate the risk.
- B. Meet with the team, remind them of the change control process, and conduct a risk assessment.
- C. Inform the contractor that the unauthorized design changes will be removed from the contract.
- D. Review and approve the change, update the budget and schedule, and proceed with the project.

Answer: (SHOW ANSWER)

Section: Monitoring and Controlling

NEW QUESTION: 46

A client is structured as a matrix organization for an agile project. The project manager is working on-site with key stakeholders from different parts of the organization. How should the project manager handle the different stakeholders?

- A. Because there are different perspectives perform a stakeholder analysis and act based on the outcome.
- B. This is an agile project, so listen only to the directions of the project manager's supervisor and the functional managers of the organization
- C. The project manager is working on the client's premises, so follow the directions of all the key stakeholders
- D. All stakeholders are important, so the project manager should follow directions provided by management and key stakeholders

Answer: A (LEAVE A REPLY)

Valid PMP Dumps shared by BraindumpsPass.com for Helping Passing PMP Exam!
BraindumpsPass.com now offer the **newest PMP exam dumps**, the BraindumpsPass.com PMP exam **questions have been updated** and **answers have been corrected** get the **newest** BraindumpsPass.com PMP dumps with Test Engine here:
<https://www.braindumpsPass.com/PMI/PMP-practice-exam-dumps.html> (1440 Q&As Dumps, **40%OFF Special Discount: Exam-Tests**)

NEW QUESTION: 47

A project manager developed a project management plan for a team composed of members based in three countries. The project manager assumed a 40 hour work week for all team members However, during project execution, the project manager teams that one country's team members work a 35-hour week Where should this information have been captured?

- A. Legal requirements documentation
- B. Response, account. consultant, and inform (RAC) chart
- C. Organizational process assets
- D. Enterprise environmental factors

Answer: D (LEAVE A REPLY)

NEW QUESTION: 48

Which process involves monitoring the status of the project to update the project costs and managing changes to the cost baseline?

- A. Estimate Costs
- B. Control Costs
- C. Determine Budget
- D. Plan Cost Management

Answer: B (LEAVE A REPLY)

Section: Monitoring and Controlling

NEW QUESTION: 49

At the completion of a project, customer agreement cannot be achieved through negotiations, what should the project manager do next?

- A. Initiate litigation since all work was completed.
- B. Explore arbitration.
- C. Inform project team members
- D. Start the closing phase.

Answer: B (LEAVE A REPLY)

NEW QUESTION: 50

You are a project manager for a telecommunications firm. You're working on a project that entails upgrading technical hardware and equipment. The estimated cost of the hardware and equipment is \$1,725,000. You are reviewing products from three vendors. One of the vendors offers you and your family the use of the company yacht for the upcoming three-day weekend. What is the most appropriate response?

- A. Thank them, and accept. Immediately report your actions to the project sponsor so that your motives are not called into question after the fact.
- B. Thank them, and decline. You know this could be considered an integrity issue on the part of the vendor.
- C. Thank them, and decline. You know this could be considered personal gain, which could call your integrity into question.
- D. Thank them, and accept. You don't believe there is a conflict of interest or an integrity issue at stake.

Answer: C (LEAVE A REPLY)

The best response to this situation is to thank the vendor and decline based on the fact that this could be considered personal gain on your part. Answer D might seem correct, but remember, you're not responsible for the integrity of others. And it's often common business practice for vendors to offer gifts to potential customers.

NEW QUESTION: 51

An input to the scope planning process is:

- A. Product description
- B. Historical information
- C. Strategic plan
- D. Project schedule

Answer: A (LEAVE A REPLY)

NEW QUESTION: 52

The scope of a project cannot be defined without some basic understanding of how to create the specified:

- A. objectives
- B. schedule

- C. product
- D. approach

Answer: ([SHOW ANSWER](#))

Section: Initiation

NEW QUESTION: 53

Outputs of the Control Communications process include:

- A. expert judgment and change requests
- B. issue logs and organizational process assets updates
- C. work performance information and change requests
- D. project management plan updates and work performance information

Answer: ([SHOW ANSWER](#))

NEW QUESTION: 54

The number of potential communication channels for a project with 5 stakeholders is:

- A. 24.
- B. 10.
- C. 20.
- D. 12.

Answer: B ([LEAVE A REPLY](#))

NEW QUESTION: 55

You are a personnel management specialist recently assigned to a project team working on a team-based reward and recognition system. The other team members also work in the human resources department. The project charter should be issued by_____.

- A. The project manager
- B. The client
- C. A sponsor
- D. A member of the PMO who has jurisdiction over human resources

Answer: C ([LEAVE A REPLY](#))

Section: Mix Questions

Explanation:

The project charter should be issued by a project initiator or sponsor who formally authorizes the project and provides the project manager with the authority to apply organizational resources to project activities. The project charter should not be issued by the project manager, although, the project manager can assist in its development.

NEW QUESTION: 56

In a project, one core team member tends to do all the work and ensures all tasks are completed. This core team member is soon leaving the project, which may make the project vulnerable. What should the project manager do?

- A. Ensure the activities of this team member are distributed across the project team.
- B. Assess a mechanism for knowledge transfer among the team members.
- C. Ask human resources (HR) to counsel the team member to balance the workload.
- D. Motivate the team member to stay by providing them with incentives.

Answer: B ([LEAVE A REPLY](#))

NEW QUESTION: 57

The budget office has informed a project manager that cost variances for every project will be monitored at the work package level. What should the project manager do during the cost estimating activity in the project to make it possible to control cost at the work package level?

- A. Use parametric estimating
- B. Estimate percent complete
- C. Use the work breakdown structure (WBS)
- D. Use analogous estimating

Answer: C ([LEAVE A REPLY](#))

NEW QUESTION: 58

You are a new project manager at a utility. In working on your first project you are referring to the project templates, company glossary, ABT Workbench Manual, and archives from previous projects. These tools are helping you with:

- A. Project plan execution
- B. Project plan coordination
- C. The "soft" tools of project management
- D. Project planning methodology

Answer: ([SHOW ANSWER](#))

NEW QUESTION: 59

During planning, a project team documented the possibility that new hardware could arrive up to 45 days late and delay the project's delivery date. One month into the project, the manufacturer notifies the project manager that the hardware will be shipped 20 days sooner than anticipated. What should the project manager do next?

- A. Adjust the procurement statement of work (SOW).
- B. Issue a change request.
- C. Update the risk register.
- D. Modify the budget.

Answer: ([SHOW ANSWER](#))

Section: Planning

NEW QUESTION: 60

How many Project Management Process Groups are there?

- A. 5

- B. 6
- C. 3
- D. 4

Answer: A ([LEAVE A REPLY](#))

NEW QUESTION: 61

In WBS diagramming, the work package is:

- A. Lowest level task to be completed
- B. Collection of the lower level tasks to be completed.
- C. Collection of tasks to be done by one individual or group
- D. All the tasks to be done by one organizational unit.
- E. All of the tasks in the project.

Answer: ([SHOW ANSWER](#))

B is probably the closest to correct. The only way I can see C being selected is because the Work Package could be handed off to another group to actually do the work. (Don't you think answer b or a would be appropriate since Work Package is the lowest level in the WBS.)

Valid PMP Dumps shared by BraindumpsPass.com for Helping Passing PMP Exam!
BraindumpsPass.com now offer the **newest PMP exam dumps**, the BraindumpsPass.com PMP exam **questions have been updated** and **answers have been corrected** get the **newest** BraindumpsPass.com PMP dumps with Test Engine here:
<https://www.braindumpsPass.com/PMI/PMP-practice-exam-dumps.html> (1440 Q&As Dumps, **40%OFF Special Discount: Exam-Tests**)

NEW QUESTION: 62

Market conditions and published commercial information are examples of which input to the Estimate Costs process?

- A. Organizational process assets
- B. Risk register
- C. Enterprise environmental factors
- D. Scope baseline

Answer: C ([LEAVE A REPLY](#))

NEW QUESTION: 63

A measure of cost performance that is required to be achieved with the remaining resources in order to meet a specified management goal and is expressed as the ratio of the cost needed for finishing the outstanding work to the remaining budget is known as the:

- A. budget at completion (BAC)
- B. earned value management (EVM)

- C. to-complete performance index
- D. cost performance index

Answer: ([SHOW ANSWER](#))

Section: Monitoring and Controlling

NEW QUESTION: 64

Which tool or technique measures performance of the project as it moves from project initiation through project closure?

- A. Earned value
- B. Resource leveling
- C. Parametric measuring
- D. Pareto chart

Answer: ([SHOW ANSWER](#))

NEW QUESTION: 65

You have been hired as a contract project manager for Grapevine Vineyards. Grapevine wants you to design an Internet wine club for its customers. Customers must register before being allowed to order wine over the Internet so that legal age can be established. You know that the module to verify registration must be written and tested using data from Grapevine's existing database. This new module cannot be tested until the data from the existing system is loaded. You are going to hire a vendor to perform the programming and testing tasks for this module to help speed up the project schedule. Since they'll have access to your customer list and potentially other trade secrets, you'll asked them to sign a nondisclosure agreement. This is an example of which of the following?

- A. Procurement documents
- B. Standard form
- C. Organizational process asset
- D. Fixed cost contract

Answer: B ([LEAVE A REPLY](#))

Standard forms are a tool and technique of the Plan Contracting process. Standard forms can be nondisclosure agreements, standardized contracts, and so on.

NEW QUESTION: 66

When a project is undertaken to reduce defects in a product or service, the objective of the project is to create a/an:

- A. portfolio
- B. improvement
- C. program
- D. result

Answer: B ([LEAVE A REPLY](#))

NEW QUESTION: 67

During a project's planning phase, a functional manager becomes anxious about the impact of the project on team morale and constantly reaches out the project manager with these concerns.

- A. Expand the project management information system, (PMIS) to allow members to communication their concerns to the functional manager.
- B. Discuss the functional manager's concerns with the e sponsor.
- C. Review the stakeholder engagement plan to ensure the functional manager's interests have been accurately recorded.
- D. Review the project charter with the team to address the functional manager's concerns.

Answer: ([SHOW ANSWER](#))

NEW QUESTION: 68

Which of the following can be used as an input for Define Scope?

- A. Project charter
- B. Scope baseline
- C. Project scope statement
- D. Product analysis

Answer: ([SHOW ANSWER](#))

NEW QUESTION: 69

Which characteristic is unique to project work and does not apply to operational work?

- A. Performed by individuals
- B. Limited by constraints
- C. Temporary
- D. Performed to achieve organizational objectives

Answer: C ([LEAVE A REPLY](#))

Section: Executing

NEW QUESTION: 70

Physical Work Actually accomplished is also called

- A. Actual Cost
- B. Budgeted Cost for Work Scheduled (BCWS)
- C. Planned Value
- D. Earned Value

Answer: D ([LEAVE A REPLY](#))

NEW QUESTION: 71

Due to a change in market conditions, the project sponsor insists on a scope change for a project that is scheduled for completion in a month. In addition, the sponsor requires that the same schedule be maintained.

What should the project manager do?

- A. Propose project crashing.
- B. Seek formal approval from the change control board (CCB).
- C. Discuss the issue with the stakeholders and modify the project management plan.
- D. Meet with the project team for ideas on how to move forward and modify the project charter.

Answer: B ([LEAVE A REPLY](#))

Section: Monitoring and Controlling

NEW QUESTION: 72

A project manager identifies a risk that a product could endanger its users. A risk response has been proposed that will decrease the product RC4 by 10 percent, but the project will still meet financial requirements. What should the project manager do?

- A. Avoid the risk because endangering users will expose the company to negative publicity
- B. Accept the risk and use any remaining funding from the project to deal with the sequences.
- C. Mitigate the risk by adding warning labels to the product
- D. Transfer the risk to the user so it does not affect the project

Answer: A ([LEAVE A REPLY](#))

NEW QUESTION: 73

The project scope baseline should be used in the identify risks process because it _____

- A. Identifies project assumptions
- B. Identifies all work that must be done; therefore, it includes all risks on the project
- C. Helps organize all work that must be done on the project
- D. Contains information on risks from prior projects

Answer: ([SHOW ANSWER](#))

Section: Mix Questions

Explanation:

Project assumptions, which should be enumerated in the project scope baseline in the scope statement, are areas of uncertainty, and therefore, potential causes of project risk.

NEW QUESTION: 74

The work breakdown structure which is an output of scope definition is

- A. A multi-oriented grouping of project components that organizes and defines the total scope of the project
- B. A object-oriented grouping of project components that organizes and defines the total scope of the project
- C. A deliverable-oriented grouping of project components that organizes and defines the total scope of the project
- D. Is a listing of items outside the scope management plan which will need to be included in the project planning phase/requirements

Answer: ([SHOW ANSWER](#))

NEW QUESTION: 75

A project manager plans the agenda for a kick-off meeting. As one of the first agenda items, the project manager wants to set the strategic direction of the project.

Who should present this topic?

- A. Functional manager
- B. Customer
- C. Project manager
- D. Project sponsor

Answer: D ([LEAVE A REPLY](#))

NEW QUESTION: 76

Communication is the PRIME responsibility of a Project:

- A. Manager in a projectized environment
- B. Manager in a weak matrix
- C. Expeditor
- D. Coordinator

Answer: ([SHOW ANSWER](#)**)**

Valid PMP Dumps shared by BraindumpsPass.com for Helping Passing PMP Exam!

BraindumpsPass.com now offer the **newest PMP exam dumps**, the BraindumpsPass.com PMP exam **questions have been updated** and **answers have been corrected** get the **newest** BraindumpsPass.com PMP dumps with Test Engine here:

<https://www.braindumpsPass.com/PMI/PMP-practice-exam-dumps.html> (1440 Q&As Dumps,

40%OFF Special Discount: Exam-Tests)

NEW QUESTION: 77

Which of the following is an output of the Plan Quality process?

- A. Organizational process asset update
- B. Control chart
- C. Project document update
- D. Cost performance baseline

Answer: C ([LEAVE A REPLY](#))

NEW QUESTION: 78

Due to organizational changes: several key stakeholders are replaced by new ones in the middle of a project. As a result, numerous new requirements are raised. What should the project manager do to ensure success of the project?

- A. Emphasize to the new stakeholders that new requirements are not allowed at this stage of the project
- B. Review and prioritize new requirements with stakeholders to determine which change requests are needed.
- C. Escalate the issue to the project sponsor and seek support to keep the original requirements.
- D. Seek immediate approval to amend the project timeline and budget in order to deliver all new requirements

Answer: C ([LEAVE A REPLY](#))

NEW QUESTION: 79

A risk may be graded into different priorities by which process?

- A. Risk response planning
- B. Quantitative risk analysis
- C. Risk monitoring and controlling
- D. Qualitative risk analysis

Answer: D ([LEAVE A REPLY](#))

NEW QUESTION: 80

Which knowledge area involves organizational theory as a tool/technique?

- A. Risk Management
- B. Human Resource Management
- C. Communications Management
- D. Cost Management

Answer: B ([LEAVE A REPLY](#))

NEW QUESTION: 81

A project is on schedule, and deliverables are being provided on time. During a customer meeting, the client team complains that deliverables fail to meet agreed-upon expectations which is validated by the project team. What should the project manager do to prevent this in the future?

- A. Ask the project sponsor for a peer review of the deliverables, and enforce the project schedule
- B. Examine the work breakdown structure (WBS) and modify the project management plan to reflect customer expectations.
- C. Conduct a root cause analysis of the issue with the team
- D. Review the project management plan to ensure conformance of future deliverables

Answer: ([SHOW ANSWER](#))

NEW QUESTION: 82

A project team member wants to select specific challenging tasks in the subsequent iteration. How can the project lead help the team member in the next iteration?

- A. Ask the product owner to assign the challenging tasks.
- B. Reprioritize the challenging tasks to future sprints.

- C. Coach the team member to pick up the challenging tasks.
- D. Assign the challenging tasks to the team member.

Answer: C ([LEAVE A REPLY](#))

NEW QUESTION: 83

A project manager leads a software development project in a hybrid environment. During project planning, the project manager identified a risk where a technical resource for a critical path item may not be available when needed. One week before the resource is needed, the technical engineer had a personal emergency and had to take a leave.

What should the project manager do next?

- A. Review the business requirement with stakeholders and exclude the task assigned to the technical resource.
- B. Consult the risk register for an appropriate planned risk response and implement.
- C. Update the lessons learned report and the risk log to reflect that this risk has materialized.
- D. Revise the project management plan and move the task to a time when the technical resource will be available.

Answer: B ([LEAVE A REPLY](#))

NEW QUESTION: 84

A regression line is used to estimate:

- A. Whether or not a process is stable or has predictable performance.
- B. The central tendency, dispersion, and shape of a statistical distribution.
- C. The upper and lower specification limits on a control chart.
- D. How a change to the independent variable influences the value of the dependent variable.

Answer: ([SHOW ANSWER](#))

NEW QUESTION: 85

A project manager is assigned to a new project. Many of the project deliverables need to be outsourced.

What should the project manager use to document the project deliverables?

- A. Service level agreement (SLA)
- B. Scope management plan
- C. Statement of work (SOW)
- D. Memorandum of understanding (MOU)

Answer: C ([LEAVE A REPLY](#))

NEW QUESTION: 86

Part of being a project manager involves dealing with conflict. According to John Adams, Ph.D., there are five methods for dealing with conflict. Some of them are used for temporary fixes, some provide more permanent resolutions. Which of the following is used for temporary resolution?

- A. Problem solving

- B. Compromising
- C. Forcing
- D. Smoothing

Answer: D ([LEAVE A REPLY](#))

NEW QUESTION: 87

The overall intentions and direction of an organization with regard to quality as formally expressed by top management is a:

- A. TQM
- B. Quality Policy
- C. Quality Plan
- D. Quality Statement

Answer: B ([LEAVE A REPLY](#))

NEW QUESTION: 88

Which of the following is an output of Direct and Manage Project Execution?

- A. Project management plan
- B. Change request status updates
- C. Organizational process assets updates
- D. Work performance information

Answer: D ([LEAVE A REPLY](#))

Section: Executing

NEW QUESTION: 89

Identify Risks is part of which Process Group?

- A. Initiating
- B. Executing
- C. Planning
- D. Closing

Answer: C ([LEAVE A REPLY](#))

NEW QUESTION: 90

The primary advantage of using decision-tree analysis in project risk management is that it _____

- A. Considers the attitude of the decision maker toward risk
- B. Forces consideration of the probability of each outcome
- C. Helps to identify and postulate risk scenarios for the project
- D. Shows how risks can occur in combination

Answer: B ([LEAVE A REPLY](#))

Explanation/Reference:

Explanation:

As a graphical way to bring together information, decision-tree analysis quantifies the likelihood of failure and places a value on each decision. Usually applied to cost and time considerations, this form of risk analysis may be linked to a sensitivity analysis.

NEW QUESTION: 91

The planned work contained in the lowest level of work breakdown structure (WBS) components is known as:

- A. Work packages.
- B. Accepted deliverables.
- C. The WBS dictionary.
- D. The scope baseline.

Answer: A (LEAVE A REPLY)

Section: Planning

Valid PMP Dumps shared by BraindumpsPass.com for Helping Passing PMP Exam! BraindumpsPass.com now offer the **newest PMP exam dumps**, the BraindumpsPass.com PMP exam **questions have been updated** and **answers have been corrected** get the **newest** BraindumpsPass.com PMP dumps with Test Engine here: <https://www.braindumpsPass.com/PMI/PMP-practice-exam-dumps.html> (1440 Q&As Dumps, **40%OFF Special Discount: Exam-Tests**)

NEW QUESTION: 92

A project manager is working on a five-year US\$200 million project Procedural document management is listed as the sponsor's main requirement prioritized even above the design itself After identifying key deliverables in the form of documented designs, the project manager contracts a document controller In this case what plan is the key component of the project manager's risk management plan*?

- A. Quality management
- B. Requirements management
- C. Resource management
- D. Cost management

Answer: (SHOW ANSWER)

NEW QUESTION: 93

A project manager is managing a project that will handle sensitive data for millions of users The sponsor mentioned that, to their knowledge, the project does not seem to have any compliance requirements in their country.

What should the project manager do in this situation?

- A. Request expert advice from the compliance leader to confirm if there are any compliance requirements for the project.
- B. Conduct independent research regarding the data protection policy of the country for legal and regulatory compliance.
- C. Trust in the expertise of the sponsor and believe that there are no compliance requirements for this project.
- D. Check with The national compliance agency to determine if the project has any compliance requirements in this country

Answer: A ([LEAVE A REPLY](#))

NEW QUESTION: 94

The positive value of conflict is underestimated. Properly managed, conflict is a valuable tool, particularly when

- A. Conflictive situations are in their late stages and emotional involvement is high E.
- B. Conflict may cause a loss of status or position power
- C. Conflictive situations are in their early stages and emotional involvement is low
- D. A diversion is needed

Answer: C ([LEAVE A REPLY](#))

NEW QUESTION: 95

An element of the modern quality management approach used to achieve compatibility with the International Organization for Standardization (ISO) is known as:

- A. Historical databases.
- B. Brainstorming.
- C. Forecasting,
- D. Cost of quality.

Answer: D ([LEAVE A REPLY](#))

NEW QUESTION: 96

Reserve analysis is a tool and technique used in which process?

- A. Identify Risks
- B. Plan Risk Responses
- C. Plan Risk Management
- D. Control Risks

Answer: ([SHOW ANSWER](#))

NEW QUESTION: 97

Your team has recommended a change to the scope verification process. What's the first thing you should do?

- A. Write up a change request.

- B. Tell your team that the process has already been decided and they should follow it.
- C. Analyze the change versus the Project Management plan to see what its impact will be.
- D. Implement the change.

Answer: C ([LEAVE A REPLY](#))

You may get a question on the exam that asks what to do when you encounter a change. You always begin dealing with change by consulting the project management plan.

NEW QUESTION: 98

A project manager is using control charts to determine whether or not a process is stable or has predictable performance. The upper and lower control limits are determined by the customer. A set of 18 data points were recorded and eight consecutive data points were found to be above the mean.

What can the project manager conclude from this finding?

- A. Escalate to the project sponsor
- B. The process is out of control
- C. Adjust the control limits
- D. The process is under control.

Answer: B ([LEAVE A REPLY](#))

NEW QUESTION: 99

An input to the Plan Procurement Management process is:

- A. Source selection criteria.
- B. A stakeholder register.
- C. A records management system.
- D. Market research.

Answer: B ([LEAVE A REPLY](#))

NEW QUESTION: 100

A resource's functional manager requests confidential information about a delayed project. Because the functional manager does not have the appropriate authorization level, the resource asks permission from the project manager to share the information. What should the project manager do?

- A. Accept the request, and provide a project update to the functional manager that includes the confidential information.
- B. Train the resource on how to promote the project to the functional manager without divulging any confidential information.
- C. Reject the request but provide a project update to the functional manager that does not include confidential information.
- D. Meet with the resource and the functional manager to explain why the information cannot be shared.

Answer: B ([LEAVE A REPLY](#))

NEW QUESTION: 101

Which of the following qualifications is the most important for a project manager?

- A. Supervisory experience
- B. Negotiation skill
- C. Education in a technical field
- D. Ability to work well with others

Answer: D (LEAVE A REPLY)

Section: Mix Questions

Explanation:

Project management requires getting things done through people who generally do not report directly to the project manager. The ability to influence project team members, as well as other key stakeholders, is crucial for success.

NEW QUESTION: 102

For the following group of numbers: 80, 10, 10, 50, 70 and 90. What is the standard deviation?

- A. 10
- B. 80
- C. 35
- D. 60

Answer: C (LEAVE A REPLY)

SD = $\sqrt{\frac{\sum\{(number - mean)^2\}}{(n - 1)}}$, where n is sample size. Here, mean is $(80+10+10+50+70+90)/6 = 51.66 = 52$ (say). So, SD =

$\sqrt{\frac{\{(80-52)^2+(10-52)^2+(10-52)^2+(50-52)^2+(70-52)^2+(90-52)^2\}}{(6-1)}} = \sqrt{[6083/5]} = \sqrt{[1217]} = 35$

NEW QUESTION: 103

The cost performance baseline is typically displayed in the form of:

- A. An S-curve.
- B. A normal curve.
- C. A U-curve.
- D. A positive slope line.

Answer: A (LEAVE A REPLY)

NEW QUESTION: 104

Each project can benefit from stakeholder involvement; however, it is in both the project manager's and the teams' best interest to ensure that all project stakeholders have positive attitudes toward the project and its goals and objectives. Working as a project manager, you have a number of key stakeholders on your project.

The stakeholder that identifies potential conflicts between organizational strategies and project goals is the _____

- A. Chairperson of the Governance Board
- B. Program manager
- C. Director of the project management office
- D. Chief Operating Officer

Answer: B (LEAVE A REPLY)

Section: Mix Questions

Explanation:

Organizational strategy provides guidance and direction to project management. Portfolio managers, sponsors, or program managers identify alignment or potential conflicts between organizational strategies and project goals and communicates them to the project manager.

NEW QUESTION: 105

Which of the following is an input to the Plan Risk Responses process?

- A. Risk urgency assessment
- B. Organizational process assets
- C. Risk register
- D. Schedule management plan

Answer: (SHOW ANSWER)

Section: Executing

NEW QUESTION: 106

Which is the correct formula for calculating expected activity cost for three-point estimating?

- A. $C_e = (C_0 + 6C_m + C_p)/4$
- B. $C_e = (C_0 + C_m, + 4C_p) / 6$
- C. $C_e = (C_0 + 4C_m + C_p)/6$
- D. $C_e = (6C_0 + C_m + C_p)/4$

Answer: (SHOW ANSWER)

Valid PMP Dumps shared by BraindumpsPass.com for Helping Passing PMP Exam!

BraindumpsPass.com now offer the **newest PMP exam dumps**, the BraindumpsPass.com PMP exam **questions have been updated** and **answers have been corrected** get the **newest** BraindumpsPass.com PMP dumps with Test Engine here:

<https://www.braindumpsPass.com/PMI/PMP-practice-exam-dumps.html> (1440 Q&As Dumps,

40%OFF Special Discount: Exam-Tests)

NEW QUESTION: 107

Which type of managers do composite organizations involve?

- A. Functional managers and manager of project managers
- B. Functional managers only

- C. Project managers only
- D. Technical managers and project managers

Answer: C ([LEAVE A REPLY](#))

Section: Initiation

NEW QUESTION: 108

A Project Manager is in the execution phase of a highly visible project and a major milestone is due in three weeks. The Project Manager has discovered that a vendor's deliverable for this milestone will be five weeks late. What should the Project Manager do?

- A. Report the status of the missed milestone
- B. Halt all payments to the vendor until the deliverable is received
- C. Do not report this problem in the status meeting
- D. Meet with the team and brainstorm how to create a workaround for this problem

Answer: D ([LEAVE A REPLY](#))

NEW QUESTION: 109

What type of reward can hurt team cohesiveness?

- A. Sole-sum
- B. Win-lose
- C. Lose-win
- D. Partial-sum

Answer: B ([LEAVE A REPLY](#))

Section: Closing

NEW QUESTION: 110

You are a project manager working on a software development project. You've developed the risk management plan, identified risks, and determined risk responses for the risks. One of the risks you identified occurs, and you implement the response for that risk. Then, another risk occurs as a result of the response you implemented. What type of risk is this called?

- A. Residual risk
- B. Mitigated risk
- C. Secondary risk
- D. Trigger risk

Answer: ([SHOW ANSWER](#))

Secondary risks occur as a result of the implementation of a response to another risk.

NEW QUESTION: 111

Consider the following situation: A scope change as requested by a client after acceptance of the design has potential impact on several components of the project. What should you as the project manager do FIRST in this situation?

- A. Make the change if it is critical, regardless of its cost and impact, and inform the change control board.
- B. Convince the client to consider the request only upon completion of the original project.
- C. Estimate the impact to the cost and schedule and the approval before proceeding.
- D. Perform a detailed analysis of the impact on the cost and schedule, and call a project team meeting.
- E. Convince the client to postpone the change.

Answer: C ([LEAVE A REPLY](#))

NEW QUESTION: 112

Which of the following calculates the difference between the budget at completion and estimate at completion?

- A. CV
- B. EV
- C. VAC
- D. SV
- E. EAC

Answer: C ([LEAVE A REPLY](#))

NEW QUESTION: 113

Which of the following are inputs to the Plan Procurements process?

- A. Risk register, scope baseline, make-or-buy decisions, organizational process assets, project schedule
- B. Risk register, scope baseline, enterprise environmental factors, organizational process assets, project schedule
- C. Project management plan, qualified seller list, contract, make-or-buy decisions, teaming agreements
- D. Project management plan, qualified seller list, contract, enterprise environmental factors, teaming agreements

Answer: ([SHOW ANSWER](#))

NEW QUESTION: 114

One of your friend is a project manager at a natural gas energy company. He is managing a project for the construction and operation of pipeline facilities at

- A. Ask the previous project manager for assistance
- B. Determine stakeholders expectations and manage their influence
- C. Obtain the historical records and guidance from the PMO
- D. Ask for additional resource from his supervisor

Answer: C ([LEAVE A REPLY](#))

NEW QUESTION: 115

A new project has high uncertainty in the cost required for completion. What approach should the project manager use to determine the expected costs?

- A. Statistical techniques estimating
- B. Analogous estimating
- C. Parametric estimating
- D. Three-point estimating

Answer: D ([LEAVE A REPLY](#))

NEW QUESTION: 116

Which of the following processes involves determining and documenting which risks are likely to affect the project?

- A. Risk monitoring and control
- B. Risk management planning
- C. Risk identification
- D. Risk response planning

Answer: C ([LEAVE A REPLY](#))

NEW QUESTION: 117

All of the following statements define the role of a meeting chairperson except:

- A. Consolidates agreements.
- B. Resolves strong disagreements
- C. Controls irrelevant discussion
- D. Produces meeting agenda
- E. Initiates and concludes discussion

Answer: D ([LEAVE A REPLY](#))

NEW QUESTION: 118

A project team member wants to ensure that deliverables are compliant with the requirements. To accomplish this, the team decides to review the multiple of the test performed on different deliverables. The project manager is concerned that this process will affect the time assigned to those verification activities.

What Should the project manager use for the review?

- A. Checksheets and Pareto diagram
- B. Statistical sampling and checksheets
- C. Control charts and scatter diagram
- D. Ishikawa diagram and statistical sampling

Answer: B ([LEAVE A REPLY](#))

NEW QUESTION: 119

A project team member identifies a quality issue that may cause the product to be rejected by the customer.

However, the project sponsor wants to deliver the product.

What should the project manager do?

- A. Update the issue log.
- B. Deliver the product.
- C. Review the quality checklist.
- D. Ensure that the product meets customer requirements.

Answer: C (LEAVE A REPLY)

Section: Monitoring and Controlling

NEW QUESTION: 120

When an activity cannot be estimated with a reasonable degree of confidence, the work within the activity is decomposed into more detail using which type of estimating?

- A. Bottom-up
- B. Parametric
- C. Analogous
- D. Three-point

Answer: A (LEAVE A REPLY)

Section: Planning

NEW QUESTION: 121

Which of the following best describes why one would use a resource histogram versus a responsibility assignment matrix?

- A. Unlike the responsibility assignment matrix, a resource histogram describes the inter-dependencies among project activities.
- B. Unlike the responsibility assignment matrix, a resource histogram is helpful in tracking project costs and can be aligned with the organization's accounting systems
- C. Unlike the responsibility assignment matrix, a resource histogram shows the reporting relationships of project team members
- D. Unlike the responsibility assignment matrix, a resource histogram shows when people will do their jobs

Answer: D (LEAVE A REPLY)

Valid PMP Dumps shared by BraindumpsPass.com for Helping Passing PMP Exam!

BraindumpsPass.com now offer the **newest PMP exam dumps**, the BraindumpsPass.com PMP exam **questions have been updated** and **answers have been corrected** get the **newest** BraindumpsPass.com PMP dumps with Test Engine here:

<https://www.braindumpsPass.com/PMI/PMP-practice-exam-dumps.html> (1440 Q&As Dumps,

40%OFF Special Discount: Exam-Tests)

NEW QUESTION: 122

Activity Number	Duration:Days	Start	Finish	Dependencies
1	5	1-Jan	6-Jan	
2	7	7-Jan	14-Jan	1,FS
3	11	7-Jan	18-Jan	1,FS 2,FS
4	7	19-Jan	26-Jan	3,FS
5	4	27-Jan	31-Jan	4,FS

Based on the project scheduled, how much float is there for activity number 4?

- A. 7 days
- B. 9 days
- C. 4 days
- D. 0 days

Answer: C (LEAVE A REPLY)

NEW QUESTION: 123

You are currently analyzing the schedule for a project. You've noticed that for a certain activities in the project, large schedule variances exist. Which of the following activities are true?

- A. Such scope variances are a result of scope changes
- B. Such schedule variances may sometimes impact the schedule
- C. Not enough information is provided
- D. Such schedule variances will impact the schedule
- E. Such schedule variances will not impact the schedule

Answer: B (LEAVE A REPLY)

NEW QUESTION: 124

A project manager is preparing a project closure presentation for stakeholders. One stakeholder has a history of refusing to sign off on project closures.

What should the project manager do prior to the presentation?

- A. Talk to the stakeholder to understand any concerns.
- B. Ask all stakeholders to review a detailed report of project results.
- C. Prepare a response to that stakeholder's most likely points of concern.
- D. Ask the project sponsor to intervene with that stakeholder.

Answer: A (LEAVE A REPLY)

Section: Closing

NEW QUESTION: 125

What is the critical chain method?

- A. A schedule network analysis technique that modifies the project schedule to account for limited resources
- B. A technique to calculate the theoretical early start and finish dates and late start and finish dates
- C. A schedule compression technique that analyzes cost and schedule trade-offs to determine how to obtain the greatest amount of compression for the least incremental cost
- D. A technique to estimate project duration when there is a limited amount of detailed information about the project

Answer: A ([LEAVE A REPLY](#))

NEW QUESTION: 126

You are leading a project team to identify potential new products for your organization. One idea was rejected by management because it would not fit with the organization's core competencies. You need to recommend other products using management's guideline as _____

- A. An assumption
- B. A risk
- C. A specification
- D. A technical requirement

Answer: ([SHOW ANSWER](#))

Section: Mix Questions

Explanation:

Assumptions are factors that, for planning purposes, are considered to be true, real, or certain without proof or demonstration. They are listed in the project scope statement.

NEW QUESTION: 127

In a country with high level of violence in public, a local police officer requires a private money transfer to ensure the safety of your team. How do you react?

- A. You do not pay, but follow the chain of command and solicit a decision.
- B. You regard it as a facilitation payment and pay the person.
- C. You regard this as bribery or at least as palm greasing and do not pay.
- D. You regard the situation as a gray area and pay through an agent.

Answer: A ([LEAVE A REPLY](#))

NEW QUESTION: 128

Which tools or techniques will the project manager use for developing the project team?

- A. Negotiation
- B. Roles and responsibilities
- C. Recognition and rewards
- D. Prizing and promoting

Answer: ([SHOW ANSWER](#))

Section: Planning

NEW QUESTION: 129

A project manager is assigned to a regulatory project for their country. The deadline for delivering results in compliance with the new laws is very tight, and the project team members have not yet been assigned. One of the project manager's peers informs the project manager that a project with the same scope for a different country was completed 1 year ago.

What should the project manager do first?

- A. Complete a bottom-up estimation for the project activities.
- B. Register a new risk in the risk management plan.
- C. Ask for additional resources and review the project estimate.
- D. Review organizational process assets (OPAs) and perform analogous estimating.

Answer: ([SHOW ANSWER](#))

NEW QUESTION: 130

The process to change a contract clause is _____ the project change control system.

- A. The same as.
- B. None of the above.
- C. Integrated within.
- D. An input to.
- E. Unrelated to.

Answer: C ([LEAVE A REPLY](#))

NEW QUESTION: 131

You are a project manager for the manufacture of children's toys. Your project team is in the process of designing a new children toy for new year Christmas season. Your project team has worked together for the last six months, and has become a self directed team, with little, if any supervision required. A new member has just added to the team. Which of the following statements are true?

- A. introduction to the new team member will cause the develop team project process to start over again at the forming stage
- B. introduction to the new team member will cause the develop team project process to start over again at the storming stage
- C. introduction to the new team member have no effect on develop team project process. The team will continue in the performing stage
- D. introduction to the new team member will cause the develop team project process to start over again at the norming stage

Answer: A ([LEAVE A REPLY](#))

NEW QUESTION: 132

What is the main deliverable from the Planning phase of a project?

- A. Charter

- B. Work results
- C. Project management plan
- D. A signed contract

Answer: C ([LEAVE A REPLY](#))

Section: Mix Questions

NEW QUESTION: 133

Which knowledge area does not provide input into cost budgeting?

- A. Scope
- B. Quality
- C. Cost
- D. Time

Answer: B ([LEAVE A REPLY](#))

NEW QUESTION: 134

An input to the Perform Quantitative Risk Analysis process is the:

- A. schedule management plan.
- B. quality management plan.
- C. communications management plan.
- D. project management plan.

Answer: ([SHOW ANSWER](#))

NEW QUESTION: 135

Smoothing out resource requirements from period to period is called resource _____.

- A. Allocation.
- B. None of the other alternatives apply.
- C. Quantification
- D. Leveling.
- E. Partitioning

Answer: ([SHOW ANSWER](#))

NEW QUESTION: 136

A complex project is closing and many project team members report negative experiences. The project stakeholders from various areas of the organization may never work together again. As part of the project's requirements, the project manager must provide lessons learned. How should the project manager ensure this requirement is met?

- A. Initiate documentation of both the positive and negative experiences using the issue log and record of escalation
- B. Reach out to each project stakeholder to capture their feedback on experiences from each phase of the project
- C. Facilitate a session with the project team to review only positive experiences

D. Document only the negative experiences so that alternative approaches can be developed for future projects

Answer: ([SHOW ANSWER](#))

Valid PMP Dumps shared by BraindumpsPass.com for Helping Passing PMP Exam! BraindumpsPass.com now offer the **newest PMP exam dumps**, the BraindumpsPass.com PMP exam **questions have been updated** and **answers have been corrected** get the **newest** BraindumpsPass.com PMP dumps with Test Engine here: <https://www.braindumpsPass.com/PMI/PMP-practice-exam-dumps.html> (1440 Q&As Dumps, **40%OFF Special Discount: Exam-Tests**)

NEW QUESTION: 137

A project manager is struggling to obtain participation from key stakeholders who do not usually attend project meetings. What should the project manager do?

- A. Reschedule meetings to align with the stakeholders' availability
- B. Distribute the communications management plan
- C. Escalate the issue to senior management
- D. Set clear meeting expectations by sharing agendas in advance

Answer: C ([LEAVE A REPLY](#))

NEW QUESTION: 138

The utility of network-based schedules:

- A. All of the other alternatives apply.
- B. Facilitates "what if" exercises.
- C. Reveals interdependencies.
- D. Highlights critical activities.
- E. Provides information on resource requirements, time requirements and tradeoffs.

Answer: A ([LEAVE A REPLY](#))

NEW QUESTION: 139

A company is deploying a new solution in several countries. The new solution is of strategic importance for the countries, as it will allow them to launch new offers for their customers. The team in charge of delivering the solution announces that the expected release will be two months late.

The team deploying the solution cannot manage several deployments in parallel.

What should the deployment project manager do?

- A. Hire external, high-level-profile resources in order to deploy as initially planned.
- B. Do a risk analysis and work with all countries on a mitigation plan and a new schedule.
- C. Review project reporting and closely monitor the countries' deployment progress to inform stakeholders.

D. Ask the sponsor to add new resources to the team delivering the solution and meet the initial milestone.

Answer: B ([LEAVE A REPLY](#))

Section: Monitoring and Controlling

NEW QUESTION: 140

Which input to the Plan Risk Management process provides information on high-level risks?

- A.** Stakeholder register
- B.** Project charter
- C.** Enterprise environmental factors
- D.** Organizational process assets

Answer: B ([LEAVE A REPLY](#))

NEW QUESTION: 141

A project manager is ready to start a new project that has a clearly defined scope, assumptions, and constraints. What should the project manager do to ensure that all key stakeholders have a common understanding of the project's scope and deliverables?

- A.** Apply the action plan used in previous projects to prevent issues.
- B.** Hold a product scope definition meeting with the client.
- C.** Distribute the approved project charter.
- D.** Send weekly project status reports.

Answer: A ([LEAVE A REPLY](#))

NEW QUESTION: 142

A project manager is tasked with large deliverables that require work by several top developers over the next few weeks. Because of the size and complexity of the deliverables, the work cannot be assigned to a single person. What should the project manager do first?

- A.** Break down the deliverable by using the work breakdown structure (WBS) process to make it more manageable for task assignment
- B.** Include the situation as a risk in the risk register, identify risk impacts and possible mitigations, and monitor closely
- C.** Request additional developers to join the project team through the change control process
- D.** Assign the entire deliverable to the first available developer to lead and have them assign the work to the remaining developers

Answer: A ([LEAVE A REPLY](#))

NEW QUESTION: 143

A project manager receives a complaint from a stakeholder that they have not received formal updates on key project milestones. What should the project manager do?

- A.** Consult the communications management plan to determine if this stakeholder is required to be updated, then act accordingly.

- B. Update the risk register and note this as an assumption made
- C. Send a project report to the stakeholder and update the change management plan accordingly.
- D. Escalate the issue to the project sponsor.

Answer: A ([LEAVE A REPLY](#))

NEW QUESTION: 144

You are in the process of establishing a total cost baseline for measuring project performance. Which of the following is the LEAST helpful tool/ technique?

- A. Parametric estimating
- B. Reserve analysis
- C. Forecasting
- D. Funding limit reconciliation
- E. Cost aggregation

Answer: C ([LEAVE A REPLY](#))

NEW QUESTION: 145

In acceptance sampling, if the sample size is kept the same but the acceptance number is increased, which of the following will be true:

- A. producer's risk will decrease and consumer's risk will increase
- B. producer's risk will decrease
- C. buyer's risk will decrease
- D. vendor's risk will decrease
- E. consumer's risk will increase

Answer: A ([LEAVE A REPLY](#))

NEW QUESTION: 146

Of the following, which conflict resolution strategy is likely to yield the most productive results?

- A. Collaborating
- B. Compromising
- C. Forcing
- D. Withdrawing

Answer: A ([LEAVE A REPLY](#))

NEW QUESTION: 147

These diagrams rank-order factors for corrective action by frequency of occurrence. They are also a type of histogram.

- A. Control charts
- B. Scatter diagrams
- C. Pareto charts
- D. Process flowcharts

Answer: C ([LEAVE A REPLY](#))

Pareto charts rank-order important factors for corrective action by frequency of occurrence.

NEW QUESTION: 148

A project manager is convinced that a contractor is requesting work outside of the project's scope. What should the project manager do?

- A. Hold a project review meeting to address the issue with the project team
- B. Inform the sponsor of the issue
- C. Create a change request
- D. Review the scope statement with the contractor

Answer: D ([LEAVE A REPLY](#))

NEW QUESTION: 149

When sequencing activities, what does the common acronym FF stand for?

- A. Fixed Fee
- B. Free Float
- C. Fixed Finish
- D. Finish-to-Finish

Answer: D ([LEAVE A REPLY](#))

Section: Closing

NEW QUESTION: 150

During the execution of a maintenance project the contractor submits an offer for additional work. The project manager realizes that the activities billed are included in the initial scope of work. What should the project manager do next in this situation?

- A. Submit a change request to approve the offer
- B. Review the project costs and communicate this to the project sponsor
- C. Refuse the offer as it is included in the initial project scope
- D. Review the project scope and negotiate with the contractor

Answer: ([SHOW ANSWER](#))

NEW QUESTION: 151

A project manager needs to decide whether to perform engineering design in-house or to outsource it.

What plan should help guide this decision?

- A. Resource management
- B. Procurement management
- C. Schedule management
- D. Engineering management

Answer: A ([LEAVE A REPLY](#))

Section: Planning

Valid PMP Dumps shared by BraindumpsPass.com for Helping Passing PMP Exam!
BraindumpsPass.com now offer the **newest PMP exam dumps**, the BraindumpsPass.com PMP exam **questions have been updated** and **answers have been corrected** get the **newest** BraindumpsPass.com PMP dumps with Test Engine here:
<https://www.braindumpsPass.com/PMI/PMP-practice-exam-dumps.html> (1440 Q&As Dumps, **40%OFF Special Discount: Exam-Tests**)

NEW QUESTION: 152

A project manager meets with key stakeholders to set clear project expectations What tool or technique should the project manager use*?

- A. Multicriteria decision analysis
- B. Facilitation
- C. Product analysis
- D. Expert judgment

Answer: B (LEAVE A REPLY)

NEW QUESTION: 153

According to a new product development process, the marketing department will begin adding business and user requirements directly into agile project documents. Drag the product information on the left to the correct documents on the right

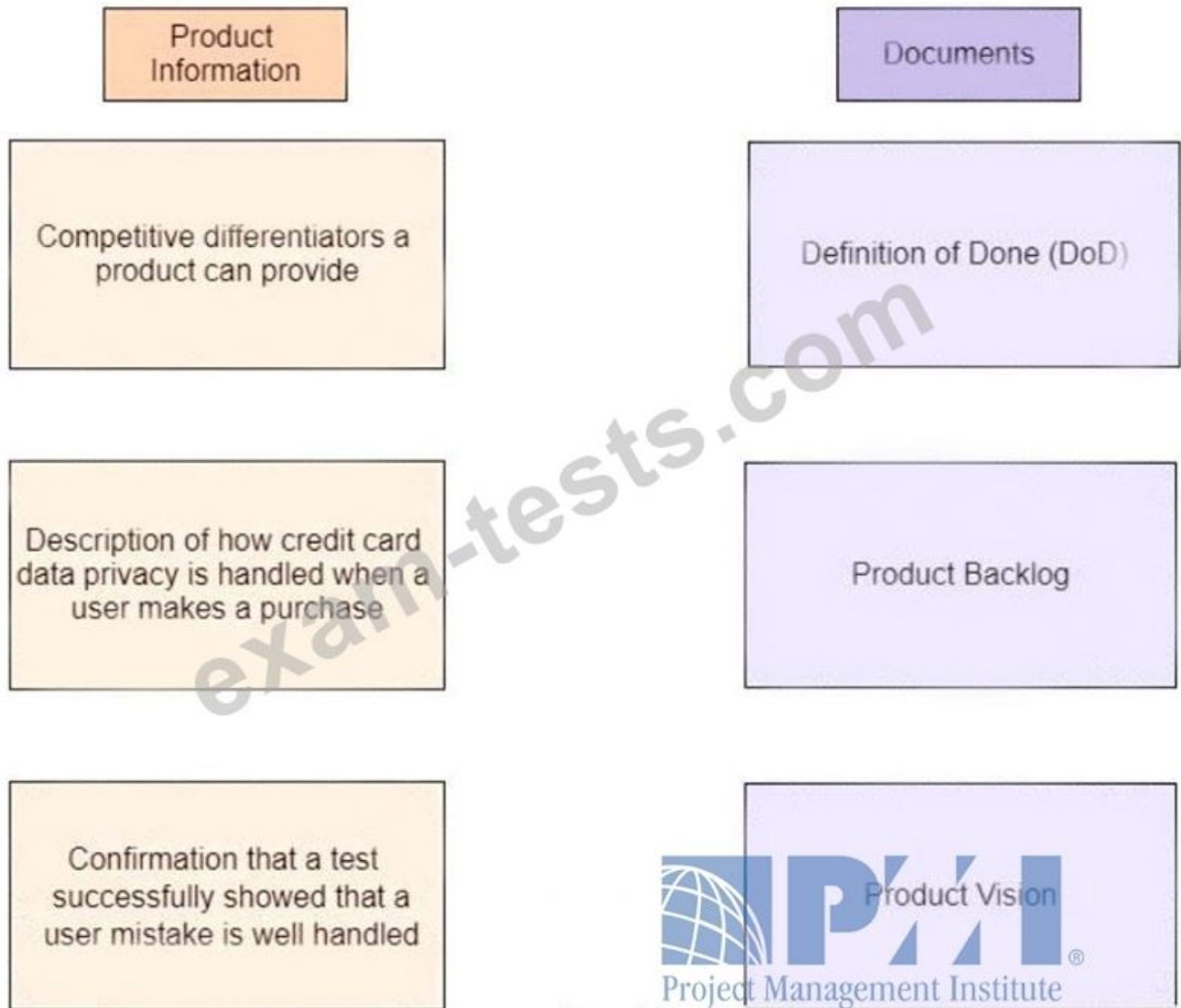

Answer:

Product Information

Competitive differentiators a product can provide

Description of how credit card data privacy is handled when a user makes a purchase

Confirmation that a test successfully showed that a user mistake is well handled

Documents

Confirmation that a test successfully showed that a user mistake is well handled

Description of how credit card data privacy is handled when a user makes a purchase

Competitive differentiators a product can provide

Documents

Confirmation that a test successfully showed that a user mistake is well handled

Description of how credit card data privacy is handled when a user makes a purchase

Competitive differentiators a product can provide

NEW QUESTION: 154

A company made several changes recently, which resulted in a positive change in the company culture. A project manager was just assigned to report to a new project supervisor whose leadership style is about getting things done quickly regardless of employee and operational impacts. Some employees are complaining about this.

What should the project manager do?

- A. Clarify expectations by explaining the company culture with the supervisor.
- B. Ask senior management to move the supervisor to a different project.
- C. Instruct the employees to listen to the supervisor.

D. Revisit the company's organizational culture.

Answer: A ([LEAVE A REPLY](#))

NEW QUESTION: 155

Contested changes are requested changes when the buyer and seller cannot agree on compensation for the change. They are also known as all but which one of the following?

- A. Disputes
- B. Demands
- C. Appeals
- D. Claims

Answer: B ([LEAVE A REPLY](#))

Section: Mix Questions

Explanation:

Claims administration is a tool and technique in the control procurements process. When the buyer and seller cannot agree, this is also called claims, disputes, or appeals and should be documented, processed, monitored, and managed throughout the contract life cycle.

NEW QUESTION: 156

Which of the following statements are FALSE regarding rolling wave plan?

- A. Rolling Wave Planning is a cost and schedule planning technique used in the Activity Definition process
- B. Rolling Wave Planning is a phased iterative approach to project development
- C. Rolling Wave Planning describes a form of progressive elaboration planning where the work to be performed in the near time is planned in detail at a low level of the WBS, while work far in future is planned for WBS components that are relatively at a high level of WBS.
- D. Rolling Wave Planning is the process of decomposing each work package within the WBS into the corresponding schedule activities required to produce the work package deliverables

Answer: D ([LEAVE A REPLY](#))

NEW QUESTION: 157

A facility improvement project is near completion. The client provided approval, but noted some minor defects and activated the warranty. The client now requests additional approved scope to equipment that has already been handed over. The project manager is about to start work on the additional scope.

Since the warranty is in effect, what plan should the project manager consult?

- A. Change management
- B. Procurement management
- C. Requirements management
- D. Quality management

Answer: B ([LEAVE A REPLY](#))

NEW QUESTION: 158

An output of the Close Project (or Close Phase) process is:

- A. accepted deliverables
- B. organizational process asset updates
- C. work performance information
- D. project management plan updates

Answer: B ([LEAVE A REPLY](#))

Section: Closing

Explanation/Reference:

NEW QUESTION: 159

A newly appointed product owner is working with a project team that is using agile for the first time. The product owner is constantly disrupting various team members throughout the day to discuss progress. This has resulted in the team feeling micromanaged and frustrated because of the constant disruptions.

How should the project manager proceed?

- A. Instruct the team to refer the product owner to the project manager for information.
- B. Invite the product owner to attend daily standup meetings so they can assess progress.
- C. Invite the product owner's functional manager to a feedback session to escalate the issue.
- D. Set up a feedback session with the product owner once a week so they can assess progress.

Answer: ([SHOW ANSWER](#))

NEW QUESTION: 160

You are the project manager at a large accounting firm in the United States. Throughout the year your firm provides both consulting services and accounting/ auditing services to XYZ Widgets, Inc, a publicly traded company listed on the New York Stock Exchange. Currently, your project involves auditing the financial statements of XYZ Widgets Inc, in preparation for the annual shareholders/ investors meeting. While your team is in the midst of project execution, you are informed that your project is due to new SEC regulations. Specifically, a new SEC regulation prohibits accounting firms from providing both consulting services and auditing services to a client, due to potential conflicts of interest that could arise from such business relationships. Hence your project is cancelled and your project team consisting of accountants and auditors are taken off your project and reassigned to another project. Which of the following statements are true?

- A. Since the project ended due to starvation, you should document the level and degree of completeness during the scope verification process
- B. Since the project ended due to integration, scope verification process is no longer necessary
- C. Since the project ended due to integration, you should document the level and degree of completeness during the scope verification process
- D. Since the project ended due to extinction, you should document the level and degree of completeness during the scope verification process

E. Since the project ended due to extinction, scope verification process is no longer necessary

Answer: C ([LEAVE A REPLY](#))

NEW QUESTION: 161

A project manager is working with an agile team to enhance a product. Due to a tight deadline, the team is trying to crash the schedule by engaging multiple resources to work on the project simultaneously. However, the technical environment is configured to allow only one resource to work on a feature at a time. The team plans to upgrade the technical environment but is unable to agree on a way forward.

What should the project manager do first?

- A. Add this conflict to the agenda for discussion at the next daily standup meeting.
- B. Escalate the issue to the product owner for resolution.
- C. Conduct a consensus-building session to decide how to approach the next set of work.
- D. Conduct a planning session to decide how to approach the next set of work.

Answer: D ([LEAVE A REPLY](#))

NEW QUESTION: 162

A newly commissioned project has had trouble recruiting team members because the turnover rate is high. The human resource (HR) manager has conducted several exit interviews. Many team members have expressed that the project manager has inadequate relationship management competencies. The project manager explains that the exiting team members were lazy.

What should the project manager do to prevent this high turnover rate from continuing?

- A. Be more involved in the team member recruitment process to ensure qualified team members are chosen.
- B. Develop relationship skills as a leader and also develop the teams' emotional intelligence skills.
- C. Avoid micromanaging the team, enforce stricter rules, and monitor employees.
- D. Explain to the recruiting manager that a project is temporary in nature, making it different than an operational environment.

Answer: ([SHOW ANSWER](#))

NEW QUESTION: 163

A project manager is reviewing the cost management plan written by a team member. Although the total cost estimate is within the approved budget, the team member used their own template rather than the one provided for the project.

What should the project manager have done?

- A. Ensured that the correct tools and techniques were used for the cost estimate
- B. Requested that the project management information system (PMIS) rules and guidelines be followed
- C. Mandated that the organizational process assets were followed

D. Required that a subject matter expert (SME) is included in the process

Answer: A ([LEAVE A REPLY](#))

Section: Planning

Explanation/Reference:

NEW QUESTION: 164

After identifying a new risk, a project manager wants to determine its impact on project objectives
What should the project manager use to accomplish this?

- A. Risk breakdown structure (RBS)
- B. Probability and impact matrix
- C. Risk register
- D. Lessons learned repository

Answer: ([SHOW ANSWER](#))

NEW QUESTION: 165

The project sponsor indicates to the project manager that due to other priorities, the budget for the project will be cut in half. This decision will cause changes in the project What should the project manager do next'

- A. Document the changes and follow the change control process.
- B. Report the impact of the changes to the sponsor.
- C. Update the project's scope management plan.
- D. Organize a meeting with the sponsor and analyze the impact on scope

Answer: A ([LEAVE A REPLY](#))

NEW QUESTION: 166

A project manager identifies a risk for a complex module in a project Before executing work on this module, a technical specialist suggests adopting a proven technology rather than using a new. experimental technology.

The project manager accepts this suggestion.

What risk response strategy did the project manager use?

- A. Avoid
- B. Share
- C. Mitigate
- D. Transfer

Answer: C ([LEAVE A REPLY](#))

Valid PMP Dumps shared by BraindumpsPass.com for Helping Passing PMP Exam!
BraindumpsPass.com now offer the **newest PMP exam dumps**, the BraindumpsPass.com
PMP exam **questions have been updated** and **answers have been corrected** get the

newest BraindumpsPass.com PMP dumps with Test Engine here:

<https://www.braindumpsPass.com/PMI/PMP-practice-exam-dumps.html> (1440 Q&As Dumps,

40%OFF Special Discount: Exam-Tests)

NEW QUESTION: 167

Which cost is associated with nonconformance?

- A. Training
- B. Inspections
- C. Liabilities
- D. Equipment

Answer: C (LEAVE A REPLY)

NEW QUESTION: 168

What provides information regarding the ways people, teams, and organizational units behave?

- A. Organizational chart
- B. Organizational structure
- C. Organizational theory
- D. Organizational behavior

Answer: C (LEAVE A REPLY)

NEW QUESTION: 169

Sensitivity analysis is typically displayed as a/an:

- A. Pareto diagram.
- B. Tornado diagram.
- C. Ishikawa diagram.
- D. Decision tree diagram.

Answer: B (LEAVE A REPLY)

NEW QUESTION: 170

Which types of Organizational Charts can be best used to track project costs:

- A. Organizational Breakdown Structure
- B. Resource Breakdown Structure
- C. Hierarchical-type Organizational Chart
- D. Responsibility Assignment Matrix

Answer: (SHOW ANSWER)

Resource Breakdown Structure is a type of hierarchical chart breaks down the project by resource types so that the project manager can see quickly which resources can be grouped together. The RBS does not have to be only for human resources and may include materials, communication technologies, and other types of resources needed to execute the project. A RBS can be aligned with Organization's accounting system.

NEW QUESTION: 171

You are managing a project and the sponsor has removed the previous Project Manager on the project because they could not keep the project on budget. According to your current project budget, this project is over budget by \$245,000. As the current Project Manager, you are afraid you will also be removed if you report this status. What is the best response you can tell senior management?

- A. Don't report the delay and begin looking for a new job
- B. Tell senior management the project is over budget by \$245,000 with a plan to recover
- C. Report the delay to senior management and the reasons
- D. The schedule is only two weeks behind so you don't report the delay

Answer: ([SHOW ANSWER](#))

NEW QUESTION: 172

A team is having a hard time completing work due to unclear requirements. They have not been able to complete an iteration successfully in several months.

In order to help the team, what should the project leader do?

- A. Recommend that the product owner reviews the backlog refinement processes.
- B. Recommend that the team reviews the length of the iteration with the stakeholders.
- C. Recommend a review of the team members' individual performances.
- D. Recommend limiting the work in progress to improve the team's focus.

Answer: A ([LEAVE A REPLY](#))

NEW QUESTION: 173

A company's project management office (PMO) is incorporating more adaptive technologies and has hired a new project manager with hybrid project management experience. The team is slow in adopting the new methodology and has not been updating project artifacts in a timely manner.

Which action should the project manager take to improve the team's performance?

- A. Send an email asking all project team members to complete updates at the end of the day
- B. Reach out to the functional managers for support
- C. Speak individually with each project team member about making the needed updates
- D. Set up a training session for all project team members

Answer: D ([LEAVE A REPLY](#))

NEW QUESTION: 174

You are in the process of developing an approved project schedule that will serve as a baseline against which the project can be tracked. All of the following can be required as part of schedule development EXCEPT:

- A. Leads and lags
- B. Performance measurements
- C. Network diagram
- D. Reserves

E. Resource calendars

Answer: ([SHOW ANSWER](#))

NEW QUESTION: 175

During the execution of a US\$20 million project in a balanced matrix structure, a subject matter expert (SME) is pulled by their department manager. What should the project manager do to complete the project on time?

- A. Update the resource management plan
- B. Negotiate with the department manager for a replacement.
- C. Escalate the issue to the department manager's line manager.
- D. Refer the issue to the project management office (PMO).

Answer: B ([LEAVE A REPLY](#))

Section: Executing

NEW QUESTION: 176

The project charter has just been signed off. There were items in the charter that described market conditions which could affect the project and also resource limitations on the project. These are examples of what?

- A. Assumptions
- B. Constraints
- C. Economic consumption
- D. Authority level of the Project Manager

Answer: ([SHOW ANSWER](#))

Section: Mix Questions

NEW QUESTION: 177

The following is a network diagram for a project.

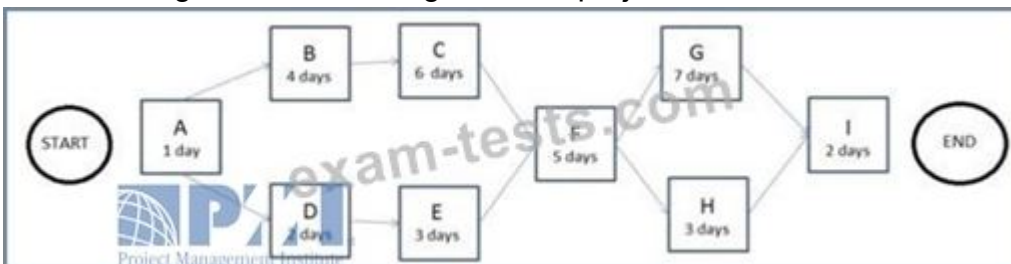

The free float for Activity E is how many days?

- A. 8
- B. 3
- C. 5
- D. 2

Answer: ([SHOW ANSWER](#))

NEW QUESTION: 178

An established project team with a good track record has been working on a project for one year. The project manager trusts the team and the work they produce. Which term describes the project manager's management approach?

- A. Transactional
- B. Charismatic
- C. Transformational
- D. Laissez-faire

Answer: D ([LEAVE A REPLY](#))

NEW QUESTION: 179

The process of prioritizing risks for further analysis or action is known as:

- A. Plan Risk Responses.
- B. Perform Quantitative Risk Analysis.
- C. Plan Risk Management.
- D. Perform Qualitative Risk Analysis.

Answer: ([SHOW ANSWER](#))

NEW QUESTION: 180

A project manager is well informed on the industry standards of the organization and believes that they are not reflected in the project deliverables. What should the project manager review next?

- A. Project charter
- B. Quality management plan
- C. Quality process
- D. Organizational process assets (OPAs)

Answer: D ([LEAVE A REPLY](#))

NEW QUESTION: 181

A project manager creates an intranet project repository available to all stakeholders. The expectation is that all updated documents will be shared via this repository. What type of communication does this describe?

- A. Network
- B. Interactive
- C. Broadcast
- D. Pull

Answer: D ([LEAVE A REPLY](#))

Valid PMP Dumps shared by BraindumpsPass.com for Helping Passing PMP Exam!
BraindumpsPass.com now offer the **newest PMP exam dumps**, the BraindumpsPass.com
PMP exam **questions have been updated** and **answers have been corrected** get the

newest BraindumpsPass.com PMP dumps with Test Engine here:

<https://www.braindumpsPass.com/PMI/PMP-practice-exam-dumps.html> (1440 Q&As Dumps,

40%OFF Special Discount: Exam-Tests)

NEW QUESTION: 182

On a transformational project, the project manager is confronted with resistance from the stakeholders. To overcome this and gain acceptance of the change, what should the project manager do first?

- A. Neutralize the negative stakeholders.
- B. Review the stakeholder engagement plan.
- C. Update the issue log.
- D. Escalate the issue to the project sponsor.

Answer: B ([LEAVE A REPLY](#))

NEW QUESTION: 183

You are the project manager within an information technology department of a large retailer. You are responsible for updating the network infrastructure of the company. As a project manager, you are in the Select Sellers process, and have four different vendors on your qualified sellers list. One of the vendors on your list has invited you to lunch to a very highclass and expensive restaurant. In fact, a meal can cost anywhere from \$500-\$1000 USD. What should you do?

- A. You should review your company's policy on the type of gifts you can accept
- B. You can accept the invitation, since such lunch invitations are generally okay, regardless of how expensive the meal is.
- C. You should decline the invitation, as you have not selected a vendor yet. This may give an unfair advantage to the seller
- D. You can accept the invitation, as there shouldn't conflict of interest with this invitation
- E. You should decline the invitation, as this may give appearance of impropriety

Answer: A ([LEAVE A REPLY](#))

NEW QUESTION: 184

Activity resource requirements and resource breakdown structure are outputs from what Project Time Management process?

- A. Schedule Control
- B. Activity Definition
- C. Schedule Development
- D. Activity Resource Estimating

Answer: D ([LEAVE A REPLY](#))

Section: Initiation

NEW QUESTION: 185

What is the lowest level in a work breakdown structure?

- A. Project task
- B. Work package
- C. None of the other alternatives apply
- D. SOW

Answer: B (LEAVE A REPLY)

A work package is the lowest level of a work breakdown structure.

NEW QUESTION: 186

Which of the following is a measure of the value of work completed compared to the actual cost or progress made on the project?

- A. Schedule performance index (SPI)
- B. Cost performance index (CPI)
- C. Cost variance (CV)
- D. Planned value (PV)

Answer: B (LEAVE A REPLY)

Section: Closing

NEW QUESTION: 187

The salience model is one way to classify stakeholders. In it _____

- A. Stakeholders' power, urgency, and legitimacy are used
- B. Stakeholders' level of authority and concern are used
- C. Stakeholders' active involvement and power are used
- D. Stakeholders' influence and ability to effect changes are used

Answer: A (LEAVE A REPLY)

Explanation/Reference:

Explanation:

In the salience model, stakeholders are described in classes based on their power or ability to impose their will, urgency or need for immediate action, and legitimacy or their involvement.

NEW QUESTION: 188

A new major road project is starting, and the contractor has contractually committed to submitting regular status reports and participating in integration meetings. Halfway through the project life cycle, the contractor stops participating in meetings and submitting reports, stating these items consume too much time.

What should the project manager do first?

- A. Submit a claim for not fulfilling the contract terms and handle the claim in accordance with the alternative dispute resolution.
- B. Remind the contractor that they committed to attending meetings and submitting reports per the contract.
- C. Speak with the company's lawyer and request that they demand the contractor fulfill their contractual commitments.

D. Assess the risk of the contractor not attending meetings and submitting reports for the rest of the project and escalate it to the project sponsor.

Answer: B ([LEAVE A REPLY](#))

NEW QUESTION: 189

Which following item is NOT an input to control scope?

- A. Requirements traceability matrix
- B. Work performance data
- C. Deliverables
- D. Scope management plan

Answer: C ([LEAVE A REPLY](#))

Section: Mix Questions

Explanation:

Verified deliverables that are completed and checked for correctness are inputs to validate scope.

NEW QUESTION: 190

Fixed Price contracts place more risk on the:

- A. C or D
- B. buyer
- C. owner
- D. seller
- E. contractor

Answer: A ([LEAVE A REPLY](#))

NEW QUESTION: 191

A company uses a management technique that employs quality assurance techniques to continuously improve all processes. This is called:

- A. Ishikawa Diagrams
- B. Kaizen
- C. Inspection
- D. Just In Time Management

Answer: (SHOW ANSWER)

Kaizen is a Japanese word that means "improvement" - and it's also a management technique that helps your company use problem-solving to constantly find new ways to improve. Kaizen focuses on making small improvements and measuring their impact. It's a philosophy that guides management, rather than a particular way of doing quality assurance.

NEW QUESTION: 192

A new project manager for an agile project is reviewing with an established team, some of the roles to avoid confusion on what to expect. Drag the description on the left to the role on the right

Description	Role
Discuss inter-dependencies within other projects	Product Owner
Assign acceptance criteria and set goals	Scrum Master
Assume leadership as needed	Servant Leader

Project Management Institute

Answer:

Description	Role
Discuss inter-dependencies within other projects	Assign acceptance criteria and set goals
Assign acceptance criteria and set goals	Discuss inter-dependencies within other projects
Assume leadership as needed	Assume leadership as needed

Role
Assign acceptance criteria and set goals
Discuss inter-dependencies within other projects
Assume leadership as needed

NEW QUESTION: 193

A project team is working on an agile software development project. The project manager is concerned that the virtual team may not be as effective as a colocated team at headquarters. Which two actions should the project manager leverage to ensure the team is meeting performance expectations?

(Choose two)

- A. Hold daily virtual meetings to review progress.
- B. Task functional managers to drive accountability.
- C. Implement time-keeping software for team members.
- D. Utilize a web-based kanban board.
- E. Require a monthly individual status report.

Answer: A,E (LEAVE A REPLY)

NEW QUESTION: 194

A scenario is presented in which current variances are seen as typical. Here are the figures:
 PV=800, BAC=700, EV=675, AC=750.

- A. 778
- B. 780
- C. 861
- D. 833

Answer: C (LEAVE A REPLY)

With the following

Explanation:

$EAC = [AC + (BAC - EV) / .9] = 861.11$ or 861 rounded down.[#1] In order to get this answer, you have to ADD the remaining budget (BAC - EV) to AC and THEN divide the sum by CPI. But that's contrary to what the parentheses indicate in PMBOK, that is: $EAC = AC + ((BAC - EV)/CPI)$. Now, if you were to obey the order of operation implied in PMBOK, you'd come up with 777.77 or 778 rounded up, which is answer A. So which one is it - 778 or 861?[#2] Actually, even though the formulas have a different meaning based on the context, mathematically they are the same: $EAC = BAC / CPI$ with no variance $EAC = AC + (BAC - EV) / CPI$ with variance, based on performance But, $CPI = EV / AC$, so $EAC = AC + (BAC - EV) / CPI = AC + BAC / CPI - EV / CPI = AC + BAC / CPI - EV / (EV / AC) = AC + BAC / CPI - EV * (AC / EV) = AC + BAC / CPI - AC = BAC / CPI$

Why does this work? When there is no variance, the CPI should be 1, and the EAC should be the BAC.[#3] Forget about all that and just use BAC / CPI (see derivation below): $700 / 0.9 = 778$. You are right, the book is wrong.

NEW QUESTION: 195

A project manager has been using predictive methodology for more than 10 years and is switching to an agile project. The team members have not previously worked together. After two sprints of work, the team has not achieved any outcome and there is a lot of pressure to get work done What kind of leadership style should the project manager use at this stage?

- A. A passive leadership style that allows the team to self-organize until the norming stage is reached
- B. A directive style that makes decisions for the group to reach early outcomes
- C. A democratic style that uses techniques where majority opinion prevails
- D. A leadership style that coaches people who want help and fosters greater team collaboration

Answer: D ([LEAVE A REPLY](#))

NEW QUESTION: 196

A Project Manager has completed the Scope Definition process. The customer and sponsor have shortened the schedule by four weeks and decided that the work breakdown structure will be excluded.

The Project Manager informs the customer and sponsor that this process creates the work breakdown structure for their project. Which answer best explains why the WBS is so important to a project?

- A. It provides templates that can be reused on other projects
- B. It helps in team commitment to the project
- C. It provides a hierarchical diagram of the project
- D. It is the foundation of the project

Answer: ([SHOW ANSWER](#))

Valid PMP Dumps shared by BraindumpsPass.com for Helping Passing PMP Exam!
BraindumpsPass.com now offer the **newest PMP exam dumps**, the BraindumpsPass.com PMP exam **questions have been updated** and **answers have been corrected** get the **newest** BraindumpsPass.com PMP dumps with Test Engine here:
<https://www.braindumpsPass.com/PMI/PMP-practice-exam-dumps.html> (1440 Q&As Dumps, **40%OFF Special Discount: Exam-Tests**)

NEW QUESTION: 197

An input to the scope change control process is:

- A. Work results
- B. Product defects
- C. Performance reports
- D. Customer requirements

Answer: C ([LEAVE A REPLY](#))

NEW QUESTION: 198

During the stages of team development, your team is in which stage when there is problem solving and interdependence along with achievement and synergy?

- A. Storming
- B. Forming
- C. Norming
- D. Performing

Answer: D ([LEAVE A REPLY](#))

Section: Mix Questions

Explanation:

The performing stage of team development is noted by a theme of productivity. Management skills involve consensus building, problem solving, decision making, and rewarding, with leadership shown through management by walking around, stewardship delegation, mentoring, being a futurist, and being a cheerleader/ champion.

NEW QUESTION: 199

Which of the following statements best describes attribute sampling versus variables sampling?

- A. Attribute sampling is concerned with prevention, whereas variables sampling is concerned with inspection.
- B. Attribute sampling is concerned with conformance, whereas variables sampling is concerned with the degree of conformity.
- C. Attribute sampling is concerned with special causes, whereas variables sampling is concerned with any causes.
- D. Both are the same concept.

Answer: B ([LEAVE A REPLY](#))

Explanation/Reference:

Explanation:

Attribute sampling determines whether a result does or does not conform. Variables sampling rates a result on a continuous scale to measure the degree of conformity.

NEW QUESTION: 200

The project charter is developed by:

- A. the customer
- B. the project manager
- C. senior management
- D. None of the other alternatives apply .
- E. senior management and the project manager

Answer: ([SHOW ANSWER](#))

NEW QUESTION: 201

Sensitivity analysis helps to determine which risks might have the greatest impacts on the project and will require a carefully crafted risk assessment. Your project team has identified several potential risks on your current project that could have a significant impact if they occurred. The team examined the impact of the risks by keeping all of the uncertain elements at their baseline values. Which of the following will the team use to display this information?

- A. Tornado Diagram
- B. Monte Carlo Simulation
- C. SWOT (Strength, Weakness, Opportunities, and Threat)
- D. Control Chart

Answer: A ([LEAVE A REPLY](#))

NEW QUESTION: 202

A project team is performing a post-release evaluation of a product that requires detailed feedback from seven stakeholders. Six of the stakeholders have promptly provided feedback. One of them has not provided any feedback despite numerous requests from the team. What should the project manager do in this situation?

- A. Meet with all seven of the project stakeholders and request all of their feedback.
- B. Host a meeting with the reluctant stakeholder and project team to resolve any conflict.
- C. Explain to the sponsor why the reluctant stakeholder needs to provide feedback.
- D. Schedule a meeting with the reluctant project stakeholder to obtain their feedback.

Answer: B ([LEAVE A REPLY](#))

NEW QUESTION: 203

To determine whether or not the employee correctly understands the message, the project manager needs to:

- A. obtain feedback
- B. use more than one medium
- C. All of the other alternatives apply.
- D. reduce the filtering
- E. eliminate barriers

Answer: A ([LEAVE A REPLY](#))

NEW QUESTION: 204

A design team discovers that the work breakdown structure (WBS) created by the project manager is missing key tasks. What should the project manager have done to avoid this?

- A. Created a requirements traceability matrix
- B. Reviewed historical information from previous projects
- C. Sought expert judgment from subject matter experts (SMEs)
- D. Developed an Ishikawa diagram

Answer: A ([LEAVE A REPLY](#))

NEW QUESTION: 205

Which of the following can the project manager use as a means of measuring project team effectiveness?

- A. Absenteeism
- B. Grievances
- C. Efficiency of the team
- D. Sponsor-approved salary increases
- E. Turnover of personnel

Answer: C ([LEAVE A REPLY](#))

NEW QUESTION: 206

The Preliminary Scope Statement which is an output of the Develop Preliminary Project Scope Statement process, is an input to all of the following EXCEPT:

- A. Scope verification
- B. Scope planning
- C. Scope definition
- D. Develop project management plan

Answer: A (LEAVE A REPLY)

Topic 15, Practice Exam (350 Questions)

NEW QUESTION: 207

A project requires specialized technical expertise from the engineering department. However, the senior engineer is leading a team on a separate project, and the only available resource is an entry-level engineer.

The senior engineer is highly regarded by the customer and preferred by the project manager. What should the project manager do first to obtain the senior engineer's participation in this project?

- A. Meet with the engineering department manager to discuss options for making the senior engineer available.
- B. Demand that the senior engineer is assigned to increase customer confidence in the delivery of a quality product.
- C. Develop a job description using the senior engineer's qualifications to hire a comparable senior engineer.
- D. Immediately ask the project sponsor to escalate this resource requirement.

Answer: A (LEAVE A REPLY)

Section: Planning

NEW QUESTION: 208

Your approved project schedule was based on resource leveling because of a scarcity of resources.

Management has now mandated that the project be completed as soon as possible. Which of the following methods will you use to recalculate the schedule?

- A. Resource manipulation
- B. Reverse resource allocation
- C. Critical chain scheduling
- D. Resource reallocation

Answer: D (LEAVE A REPLY)

Explanation/Reference:

Explanation:

While resource leveling will often result in a project duration that is longer than the preliminary schedule as the original critical path probably will change and increase, it can also be used to get a schedule back on track by reassigning activities from noncritical to critical path activities.

NEW QUESTION: 209

A project manager led the implementation of an electronic invoicing project that has just been completed. The financial manager communicated that the team discovered three invoices with errors. Which two documents should the project manager update as soon as possible? (Choose two)

- A. Change log
- B. Stakeholder register
- C. Risk register
- D. Issue log
- E. Backlog register

Answer: A,E (LEAVE A REPLY)

NEW QUESTION: 210

A functional manager complains that an employee is involved in too many project meetings, wasting valuable time that could be used for other responsibilities. To what document should the project manager refer to address this?

- A. Work breakdown structure (WBS)
- B. Resource calendar
- C. Network diagram
- D. Work performance report

Answer: B (LEAVE A REPLY)

Section: Executing

NEW QUESTION: 211

You are a project manager of ABC organization. There are two projects to choose the best one. Project X will take 3 years to complete and has NPV value \$70,000 and Project Y will take 5 years to complete and has NPV value \$60,000. What is the opportunity cost of selecting Project X?

- A. \$130,000
- B. \$30,000
- C. \$60,000
- D. \$35,000

Answer: (SHOW ANSWER)

opportunity cost of selecting Project X is simply the value of the project you did not select. Based on the NPV you have selected project X. Therefore value of the project Y is the opportunity cost.

Valid PMP Dumps shared by BraindumpsPass.com for Helping Passing PMP Exam!
BraindumpsPass.com now offer the **newest PMP exam dumps**, the BraindumpsPass.com PMP exam **questions have been updated** and **answers have been corrected** get the **newest** BraindumpsPass.com PMP dumps with Test Engine here:
<https://www.braindumpsPASS.com/PMI/PMP-practice-exam-dumps.html> (1440 Q&As Dumps, **40%OFF Special Discount: Exam-Tests**)

NEW QUESTION: 212

During contract negotiations on large contracts, the negotiation process focuses on many key issues, with price being one of them. Separate negotiations can be made on price, quantity, quality, and timing, which can significantly lengthen the process. The negotiation process can be shortened, however, provided that _____

- A. Planning is done for negotiations
- B. Expertise of the project management staff in the procurement process is at a high level
- C. A request for proposal is used rather than a request for quotation
- D. There is integrity in the relationship and prior history with the vendor

Answer: (SHOW ANSWER)

Section: Mix Questions

Explanation:

When people know and trust one another, and in particular have worked with each other before, the negotiation process can be significantly shortened. Three major factors of negotiation should be followed:

compromise ability, adaptability, and good faith.

NEW QUESTION: 213

A hybrid project has just started, which will result in a new technology that could disrupt the market if well accepted by the public. The product requires health and safety approvals from the government. As this is an innovative solution, the sponsor and product owner are unsure if it will be accepted by the public.

What is the appropriate flow for product development?

- A. Complete development with all functionalities in perfect condition prior to demonstrating to stakeholders to ensure a great first impression.
- B. Complete development for each sprint and demonstrate the product increment to internal stakeholders and the government, without engaging other external stakeholders.
- C. Complete development for the must-have functionalities only prior to demonstration in order to fail fast and get early feedback.
- D. Complete development for must-have functionalities only and demonstrate it to a focus group, but wait until all development is complete to demonstrate it to the government.

Answer: (SHOW ANSWER)

NEW QUESTION: 214

A high-tech borehole protect was initiated with the goal of providing water for a rural community of 1500 villagers located in an arid region. The project was completed with a cost performance index (CPI) of 1.09 and a schedule performance index (SPI) of 0.93. Six months after its completion it is determined that the villagers could not access water. What caused this situation to occur?

- A. The risk analysis was inadequate
- B. The project was completed behind schedule
- C. The requirements gathering was inadequate
- D. The project was delivered above budget

Answer: A (LEAVE A REPLY)

NEW QUESTION: 215

You are managing an internal project where a vice president from the user group is acting as the sponsor. You have just been informed by your team that the critical path has slipped by three weeks. You should:

- A. Immediately inform the sponsor and ask for advice
- B. Look for someone to blame before you see the sponsor
- C. See the sponsor after you have evaluated alternatives, recommendations, and performed an impact analysis
- D. Do nothing until the slippage occurs
- E. Inform your senior management of the problem and tell them that you will get back to them after you assessed the situation

Answer: C (LEAVE A REPLY)

NEW QUESTION: 216

Assume your project communication management plan has been approved by your sponsor and the members of your Steering Committee. You are managing a global project and have team members working virtually in four continents and stakeholders in numerous locations. Your next step is to _____

- A. Set up an information management system
- B. Select communications technology
- C. Determine performance reporting methods
- D. Select a communications model

Answer: B (LEAVE A REPLY)

Section: Mix Questions

Explanation

Explanation:

Although all four listed are tools and techniques in the manage communications process (another is communications methods), since this project is a virtual one, the choice of technology is an important consideration. It can vary from project to project and throughout the life cycle, but as the

project manager the focus is to ensure the choice is important for the information that is communicated.

NEW QUESTION: 217

A project team is having difficulties understanding technical details regarding requirements. The information was not initially provided by the customer, but the information is critical in the current iteration for clarification on how tasks need to be accomplished. How should the project manager approach this situation?

- A. Request that the customer reviews and clarifies feature definitions for the current sprint.
- B. Educate the customer and have them participate in daily standup meetings.
- C. Schedule weekly meetings and product reviews with the customer to clarify requirements.
- D. Send a burndown chart of the current sprint to the customer and seek clarifications.

Answer: C ([LEAVE A REPLY](#))

NEW QUESTION: 218

The Process Group in which the internal and external stakeholders interact and influence the overall outcome of the project is the:

- A. Initiating Process Group.
- B. Executing Process Group.
- C. Monitoring and Controlling Process Group.
- D. Planning Process Group.

Answer: A ([LEAVE A REPLY](#))

NEW QUESTION: 219

A project manager decided to use a highly adaptive approach to manage a large-scale project. In this project, there are many iterative tasks that utilize highly specialized experts. The project manager would like to create practical plans with high levels of buy-in from the team members. What should the project manager do next?

- A. Review lessons learned from similar projects with the team.
- B. Assign critical tasks to the most experienced team members.
- C. Review the budget with the team for the needed resources.
- D. Explain the higher-level objectives to be assigned to the team.

Answer: A ([LEAVE A REPLY](#))

NEW QUESTION: 220

A negative cost variance and positive schedule variance means:

- A. The project will be overrun but ahead of schedule at completion.
- B. None of the other alternatives apply.
- C. The project is over budget and behind schedule.
- D. The project is under budget and ahead of schedule.
- E. The project is over budget and ahead of schedule.

Answer: E ([LEAVE A REPLY](#))

NEW QUESTION: 221

You are beginning a new project and a portion of the development will be created by a foreign company.

You are not sure how to do business with this company because it is offshore.

What document would be best to guide you in this business?

- A. Company's policies and procedures
- B. PMI Code of Conduct
- C. Local laws of the offshore company
- D. Historical information from past projects

Answer: A ([LEAVE A REPLY](#))

Section: Mix Questions

NEW QUESTION: 222

You are the Project Manager on a project where \$4M US will be spent on procuring telecom equipment. As negotiations begin between your company and the vendor, you are approached by the vendor's sales representative who offers you a trip to Las Vegas if you can "help" the process along by ensuring that the contract has accelerated payment terms compared to typical contracts. What is your professional and social responsibility?

- A. Decline the trip until after the contract has been signed
- B. The work you have put in on the project has been demanding and you deserve the trip
- C. Decline the trip because it is not in the best interest of the company
- D. Decline the trip and have it offered to your manager

Answer: C ([LEAVE A REPLY](#))

NEW QUESTION: 223

Pure Risk differs from Business Risks because Pure Risk's _____ .

- A. must incur business liability associated with loss of pure profit.
- B. Both 1) include chances of loss and no chances for profit associated with the business and, 2) must incur personal loss with business liability
- C. must incur personal loss with business liability.
- D. include chances of loss and no chances for profit associated with the business.
- E. include chances of both profit or loss associated with the business.

Answer: ([SHOW ANSWER](#))

NEW QUESTION: 224

Excessive flexibility in specifying requirements will _____ the likelihood of time overruns.

- A. Reduce.
- B. Increase
- C. Eliminate.

- D. Double
- E. Not affect

Answer: ([SHOW ANSWER](#))

NEW QUESTION: 225

Your organization is adopting a project-based approach to business, which has been difficult. Although project teams have been created, they are little more than a collection of functional and technical experts who focus on their specialties. You are managing the company's most important project. As you begin this project, you must place a high priority on_____

- A. Creating an effective team
- B. Identifying the resources needed to finish the project on time
- C. The best way to communicate status to the CEO
- D. Establishing firm project requirements

Answer: ([SHOW ANSWER](#))

Explanation/Reference:

Explanation:

An effective team is critical to project success, but such a team is not born spontaneously. In early project phases, it is vitally important for the project manager to place a high priority on initiating and implementing the team-building process.

NEW QUESTION: 226

Diagram:

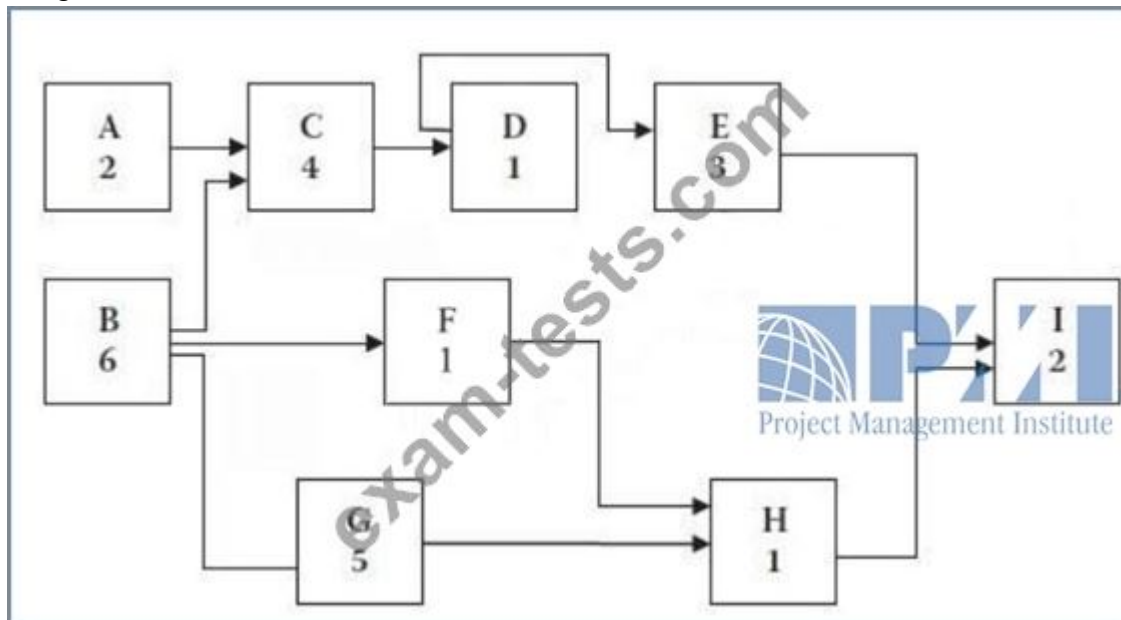

What is the float for Activity G?

- A. -2
- B. 0
- C. 1
- D. 4

Answer: C ([LEAVE A REPLY](#))

Explanation/Reference:

Explanation:

Float = (late finish - early finish) or
(Late start - early start)

Activity G LF = 12 (12 - 11) = (1)

EF = 11

LS = 7 (7 - 6) = (1)

ES = 6

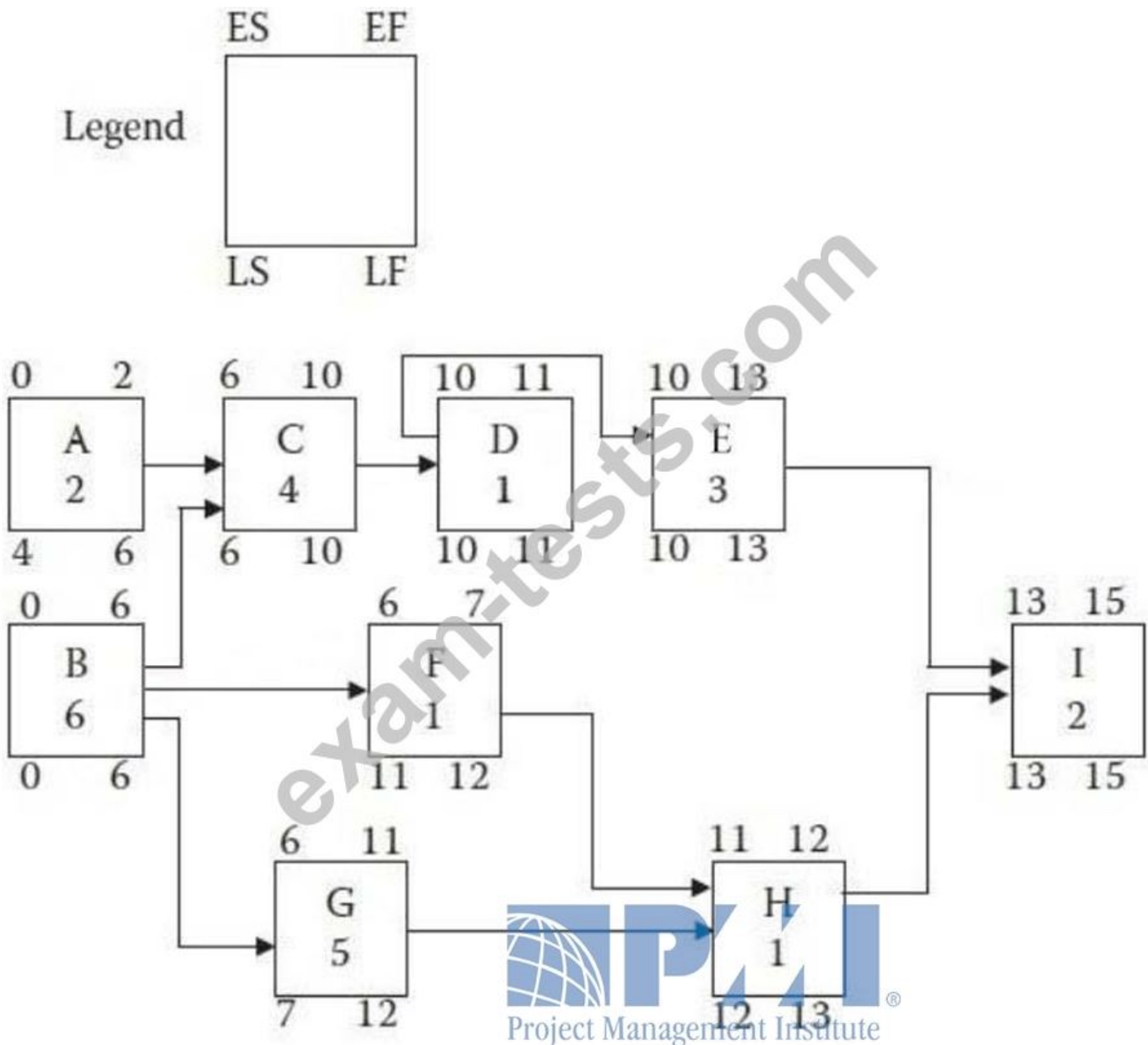

Valid PMP Dumps shared by BraindumpsPass.com for Helping Passing PMP Exam!
BraindumpsPass.com now offer the **newest PMP exam dumps**, the BraindumpsPass.com
PMP exam **questions have been updated** and **answers have been corrected** get the
newest BraindumpsPass.com PMP dumps with Test Engine here:

NEW QUESTION: 227

A client informs the project manager that a team member is unacceptable for a project that is behind schedule.

However, the client is unwilling to share their reasons.

- A. Try to convince the client to work with the team member.
- B. Meet with the client and team member to resolve the issue
- C. Replace the team member with another resource.
- D. Speak confidentially with the client to understand their concerns

Answer: D ([LEAVE A REPLY](#))

NEW QUESTION: 228

An input to the Create WBS process is a:

- A. project scope statement.
- B. stakeholder register.
- C. project charter.
- D. requirements traceability matrix.

Answer: ([SHOW ANSWER](#)**)**

NEW QUESTION: 229

Which of the following statements is in agreement with McGregor's concepts concerning Theory X and Theory Y managers?

- A. Theory X managers view subordinates as being lazy, irresponsible, and resistant to change
- B. Both 1) Theory X managers view subordinates as being lazy, irresponsible, and resistant to change, and 2) Theory Y managers view subordinates as being imaginative, creative, and willing to accept responsibility
- C. Theory X managers tend to be autocratic whereas Theory Y managers are more likely to delegate responsibility
- D. All of the other alternatives apply
- E. Theory Y managers view subordinates as being imaginative, creative, and willing to accept responsibility

Answer: D ([LEAVE A REPLY](#))

NEW QUESTION: 230

Which of the following is NOT an essential regarding a project close-out?

- A. Documenting formal acceptance of the product.
- B. Documenting the final risk assessment.
- C. Documenting the final project scope
- D. None of the above.

E. Documenting the lessons learned.

Answer: B ([LEAVE A REPLY](#))

NEW QUESTION: 231

Ishikawa diagrams are used in which of the following processes?

- A. Risk management planning
- B. Create WBS
- C. Schedule development
- D. Perform quality control

Answer: D ([LEAVE A REPLY](#))

NEW QUESTION: 232

Which of the following factors contributes the most to team communication?

- A. External feedback
- B. Performance appraisals
- C. Smoothing over of team conflicts by the project manager
- D. Collocation

Answer: D ([LEAVE A REPLY](#))

Explanation/Reference:

Explanation:

Collocation is the placement of team members in the same physical location to enhance their ability to perform as a team, primarily through increased communication as well as improved working relationships and productivity.

NEW QUESTION: 233

The product owner notifies the project manager about a risk that has been identified. What should the project manager do?

- A. Include the risk status as part of the daily standup.
- B. Include the risk-response strategy in the backlog during the refinement.
- C. Ask the agile team to stop the iteration and work on the risk-response strategy.
- D. Check the risk status in the iteration review.

Answer: B ([LEAVE A REPLY](#))

NEW QUESTION: 234

A project manager new to a project quickly notices a low level of motivation in project team members. What should the project manager do?

- A. Develop team-building exercises.
- B. Reassign the resources to other projects.
- C. Implement the Maslow pyramid.
- D. Establish ground rules.

Answer: A ([LEAVE A REPLY](#))

Section: Monitoring and Controlling

NEW QUESTION: 235

The team has reported the following impediments at the daily standup meeting Drag each impediment on the left to the action that the project manager needs to take on the right

Team Member Impediment

- I am waiting for resources from another team before I can continue on this story.
- I finished my story but found that the acceptance criteria caused a conflict with another story.
- I had to work on something that was not on the task board.

Action

- Escalate
- Create or modify a story
- Ask the product owner

Answer:

Team Member Impediment

- I am waiting for resources from another team before I can continue on this story.
- I finished my story but found that the acceptance criteria caused a conflict with another story.
- I had to work on something that was not on the task board.

Action

- I am waiting for resources from another team before I can continue on this story.
- I had to work on something that was not on the task board.
- I finished my story but found that the acceptance criteria caused a conflict with another story.

Explanation



NEW QUESTION: 236

Some members of a project team work from home. During a weekly video-conference, much time is lost due to disconnected or dropped participants, background noise, strong interference, or multiple people speaking simultaneously. People are becoming annoyed and ask not to participate.

What should the project manager do?

- A. Request that all the team members meet physically for the weekly meeting.
- B. Hold individual meetings with team members and consolidate the information in meeting minutes for distribution.
- C. Define and train the team on a set of minimum requirements, rules for home and remote offices, and meeting etiquette.
- D. Change the frequency of the weekly meetings to monthly.

Answer: B (LEAVE A REPLY)

NEW QUESTION: 237

This process can directly influence the project schedule.

- A. Human Resource Planning
- B. Plan Contracting
- C. Plan Purchases and Acquisitions
- D. Activity Sequencing

Answer: (SHOW ANSWER)

Plan Purchases and Acquisitions can directly influence the project schedule, and the project schedule can directly influence this process.

NEW QUESTION: 238

Activity cost estimates are quantitative assessments of the probable costs required to:

- A. Create WBS.
- B. complete project work.

- C. calculate costs.
- D. Develop Project Management Plan.

Answer: ([SHOW ANSWER](#))

Section: Planning

NEW QUESTION: 239

When a project manager is running over the budgeted costs, the project manager can typically _____ to attempt to get the project back on budget.

- A. All of the other alternatives apply.
- B. Increase risk.
- C. Incur a schedule slippage (to obtain more favorable pricing due to lengthened delivery times)
- D. Both 1) Reduce features and/or functionality, and 2) Increase risk
- E. Reduce features and/or functionality

Answer: ([SHOW ANSWER](#))

NEW QUESTION: 240

What is the typical role of senior management on a project?

- A. Support the project
- B. Pays for it
- C. Supports the project and resolves resource and other conflict
- D. Resolves resource and other conflicts

Answer: C ([LEAVE A REPLY](#))

Section: Mix Questions

NEW QUESTION: 241

You are in the process project a project schedule for repainted your house, you first need to scrap off the existing paint, and then add a layer of primer. The primer provides the paint a better bonding surface so it sticks to the base material much better. Without priming, drywall surfaces will soak up more finish paint in some areas than in others, producing a splotchy effect.

You decided to speed up the process by starting priming before all the scraping is finished. To correctly sequence these activities, which of the following should you do?

- A. Fast track the priming and painting tasks
- B. Add lead time to the priming task
- C. Ad lag time to the priming task
- D. Add float time between the priming and painting tasks

Answer: B ([LEAVE A REPLY](#))

Valid PMP Dumps shared by BraindumpsPass.com for Helping Passing PMP Exam!

BraindumpsPass.com now offer the **newest PMP exam dumps**, the BraindumpsPass.com

PMP exam **questions have been updated** and **answers have been corrected** get the **newest** BraindumpsPass.com PMP dumps with Test Engine here:
<https://www.braindumpsPASS.com/PMI/PMP-practice-exam-dumps.html> (1440 Q&As Dumps,
40%OFF Special Discount: Exam-Tests)

NEW QUESTION: 242

Dennis works for an international manufacturer for consumer electronics. He has been recently assigned to supervise and manage the manufacturing of a new model of flat-screen televisions. His supervisor congratulates Dennis on his expanded responsibilities. He informs Dennis that his new assignment will have the 1000 units of the new flat screen manufactured by September. Before Dennis begins manufacturing these new units he needs to determine the characteristics of his new product line, such as screen size, color, resolution e.t.c. which of the following tasks must Dennis perform prior to manufacturing the product?

- A. Fast-track the project-begin manufacturing the product while the requirements are clarified
- B. Progressive elaborations
- C. Consult the supervisor for the detailed requirements
- D. Submit a RFP to get the detailed requirements
- E. Submit a RFQ to get the detailed requirements

Answer: B (LEAVE A REPLY)

NEW QUESTION: 243

Decomposition, rolling wave planning, and templates are all tools and techniques for which of the following?

- A. Estimate Activity Durations
- B. Define Activities
- C. Sequence Activities
- D. Develop Schedule

Answer: B (LEAVE A REPLY)

NEW QUESTION: 244

Human resource administration is the primary responsibility of the:

- A. Project Manager
- B. Human Resources Department
- C. Project Management Team
- D. Executive Manager
- E. Line Managers

Answer: B (LEAVE A REPLY)

NEW QUESTION: 245

A project manager discovers that material costs have increased significantly since project initiation. To what should the project manager refer to determine if the project is still feasible?

- A. Basis of the estimate
- B. Cost baseline
- C. Cost management plan
- D. Business case

Answer: D ([LEAVE A REPLY](#))

Section: Initiation

NEW QUESTION: 246

Which of the following objectives is LEAST likely accomplish by implementing a project-wide application of the configuration management system?

- A. Provides opportunities to improve the project by considering the impact of each change
- B. Establishes a method to identify and request changes to project baseline
- C. Provides a method to identify and manage risks
- D. Provides a mechanism to communicate changes to stakeholders

Answer: C ([LEAVE A REPLY](#))

NEW QUESTION: 247

Which tool or technique allows a large number of ideas to be classified into groups for review and analysis?

- A. Idea/mind mapping
- B. Affinity diagram
- C. Brainstorming
- D. Nominal group technique

Answer: B ([LEAVE A REPLY](#))

NEW QUESTION: 248

A sponsor proposes a project scope change that is popular with the project team and key stakeholders. What should the project manager do?

- A. Follow the scope change request process.
- B. Notify stakeholders of the change.
- C. Update the project requirements.
- D. Modify the work breakdown structure (WBS).

Answer: A ([LEAVE A REPLY](#))

Section: Executing

NEW QUESTION: 249

Quality function deployment is one approach for collecting requirements. Assume that you have studied the work of numerous quality experts, such as Deming, Juran, and Crosby, and your organization has a policy that states the importance of quality as the key constraint of all project constraints. You and your team have decided to use quality function deployment on your new

project to manufacture turbines that use alternative fuels. The first step you should use is to _____

- A. Determine the voice of the customer
- B. Build the house of quality
- C. Address the functional requirements and how best to meet them
- D. Hold a focus group of prequalified stakeholders

Answer: A (LEAVE A REPLY)

Section: Mix Questions

Explanation:

Quality function deployment is an example of a facilitated workshop used in the manufacturing industry as a tool and technique to collect requirements. It helps to determine the critical characteristics for new product development and starts by collecting customer needs, known as the voice of the customer.

NEW QUESTION: 250

Which type of agreement is legal, contractual, and between two or more entities to form a partnership, joint venture, or some other arrangement as defined by the parties?

- A. Teaming
- B. Sharing
- C. Collective bargaining
- D. Working

Answer: A (LEAVE A REPLY)

NEW QUESTION: 251

Which of the following formulas calculates the number of communication channels in a project?

$$\begin{array}{l}
 \text{a. } \frac{n(n-1)}{2} \\
 \text{b. } \frac{n^2-1}{2} \\
 \text{c. } \frac{n^2-1}{n} \\
 \text{d. } \frac{2^n-2}{1^n}
 \end{array}$$

- A. Option a
- B. Option b
- C. Option c
- D. Option d

Answer: A (LEAVE A REPLY)

Explanation/Reference:

Explanation:

Where n = the number of stakeholders.

NEW QUESTION: 252

Progressive elaboration of product characteristics on your project must be coordinated carefully with the _____

- A. Proper project scope definition
- B. Project stakeholders
- C. Scope change control system
- D. Customer's strategic plan

Answer: (SHOW ANSWER)

Explanation/Reference:

Explanation:

Progressive elaboration of a project's specification must be coordinated carefully with proper scope definition, particularly when the project is performed under contract. When properly defined, the project scope the work to be done should remain constant even when the product characteristics are elaborated progressively.

NEW QUESTION: 253

A project manager is running a project to manage the election campaign for a mayoral candidate. The project manager finds it difficult to align team members of different genders.

What can the project manager use to facilitate this issue?

- A. Expert judgment
- B. Disciplinary action
- C. Enterprise environmental factors
- D. Organizational process assets

Answer: D ([LEAVE A REPLY](#))

Section: Monitoring and Controlling

NEW QUESTION: 254

The process of identifying and documenting relationships among the project activities is known as:

- A. Control Schedule.
- B. Sequence Activities.
- C. Define Activities.
- D. Develop Schedule.

Answer: B ([LEAVE A REPLY](#))

Section: Closing

NEW QUESTION: 255

After the second iteration of a component development project, the project team conducts a retrospective. It shows that in the initial phase the project has failed to comply with a product functionality. The planning for this product has a predominantly predictive approach.

Which technique will help the project manager to accelerate the deliverable?

- A. Scrum of Scrums
- B. Rolling wave planning
- C. Collective code ownership
- D. Impact mapping

Answer: B ([LEAVE A REPLY](#))

NEW QUESTION: 256

Your goal as a project manager is to manage stakeholders to the best of your ability. However, if there are conflicts among stakeholders, they should usually be resolved in favor of:

- A. Business Partner/Project Sponsor
- B. All Stakeholders
- C. Team Members
- D. Customer

Answer: ([SHOW ANSWER](#))

Valid PMP Dumps shared by BraindumpsPass.com for Helping Passing PMP Exam!
BraindumpsPass.com now offer the **newest PMP exam dumps**, the BraindumpsPass.com PMP exam **questions have been updated** and **answers have been corrected** get the **newest** BraindumpsPass.com PMP dumps with Test Engine here:
<https://www.braindumpsPass.com/PMI/PMP-practice-exam-dumps.html> (1440 Q&As Dumps, **40%OFF Special Discount: Exam-Tests**)

NEW QUESTION: 257

A project manager notices that a vendor consistently revises deliverables that provide input information to final project deliverables. The revisions are unidentified, and the team is concerned that some updates may be missed and impact dependent activities.

What should the project manager do?

- A. Ask the team to conduct detailed checks of vendor documents before implementation.
- B. Meet with the team to identify implemented updates.
- C. Inform the vendor that approved project quality procedures should be followed.
- D. Ask the vendor to provide a detailed revision history.

Answer: C (LEAVE A REPLY)

Section: Monitoring and Controlling

NEW QUESTION: 258

Which of the following is a tool and technique for activity duration estimating?

- A. Parametric estimating
- B. Bottom-up estimating
- C. Top-down estimating
- D. Monte Carlo analysis

Answer: A (LEAVE A REPLY)

NEW QUESTION: 259

Identify Risks is part of which Process Group?

- A. Closing
- B. Initiating
- C. Planning
- D. Executing

Answer: C (LEAVE A REPLY)

NEW QUESTION: 260

A project manager receives an update that the development flow is not going well. Some team members cannot start their work because the delivery is late. Looking at the Kanban board and the work in progress (WIP) lines, the project manager observes a bottleneck. Click the title of the queue in the Kanban board below that requires additional resources to relieve the bottleneck

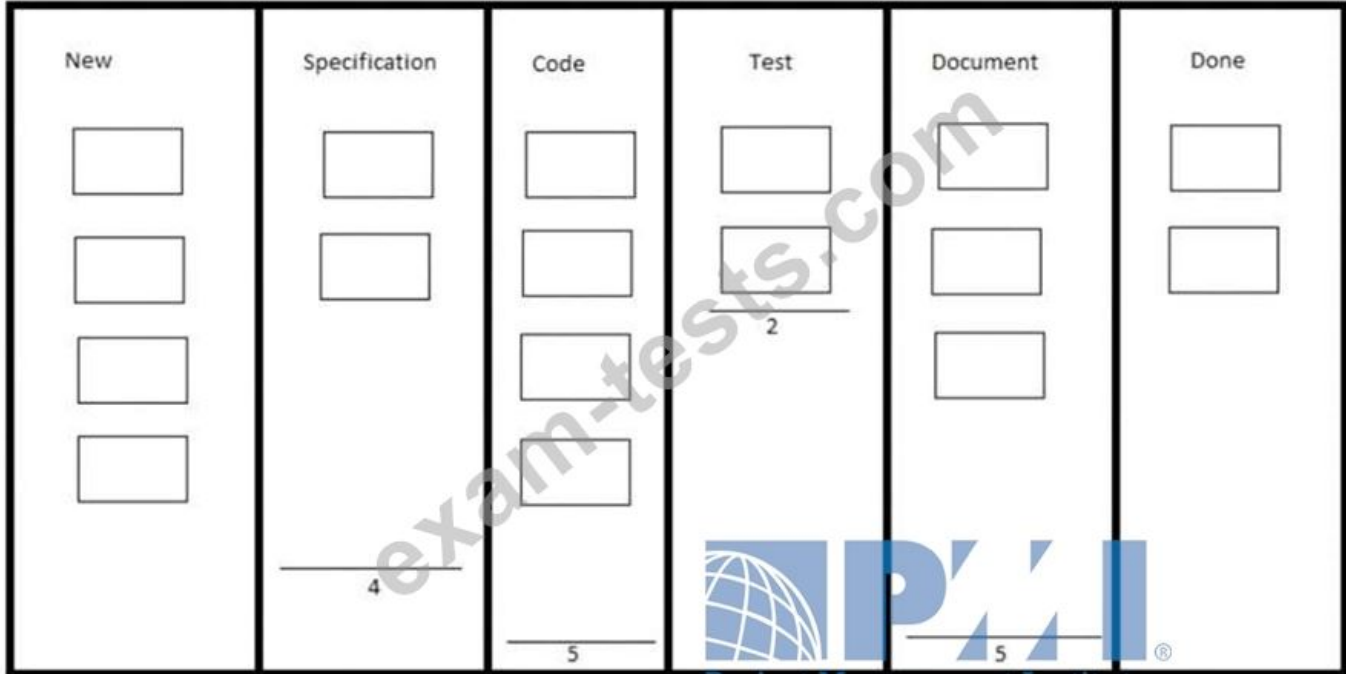

Answer:

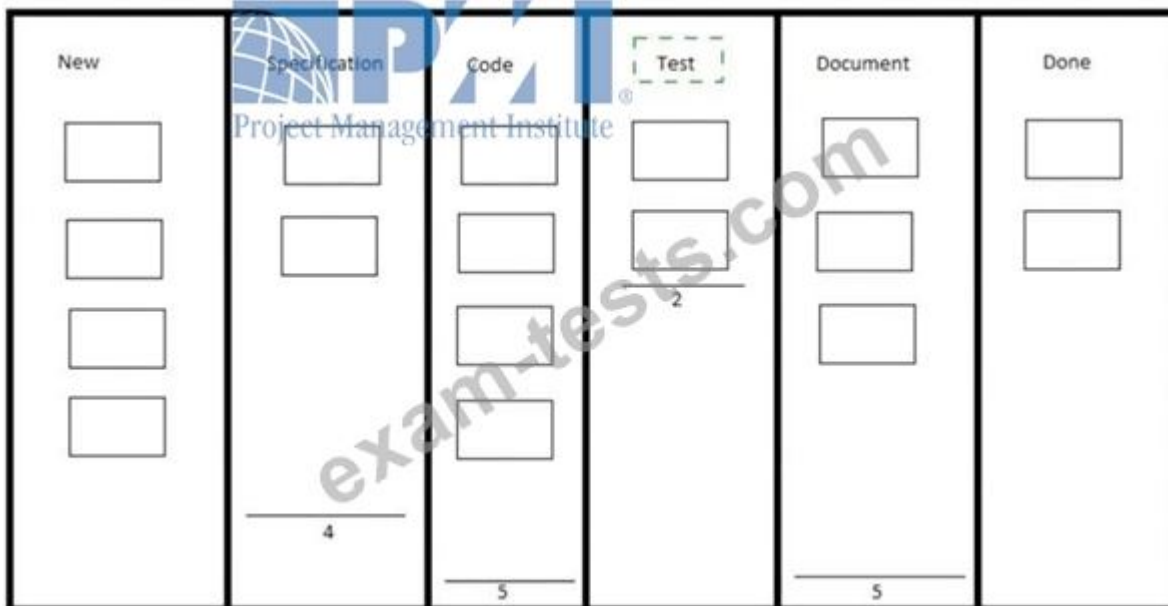

Explanation

Diagram, rectangle Description automatically generated

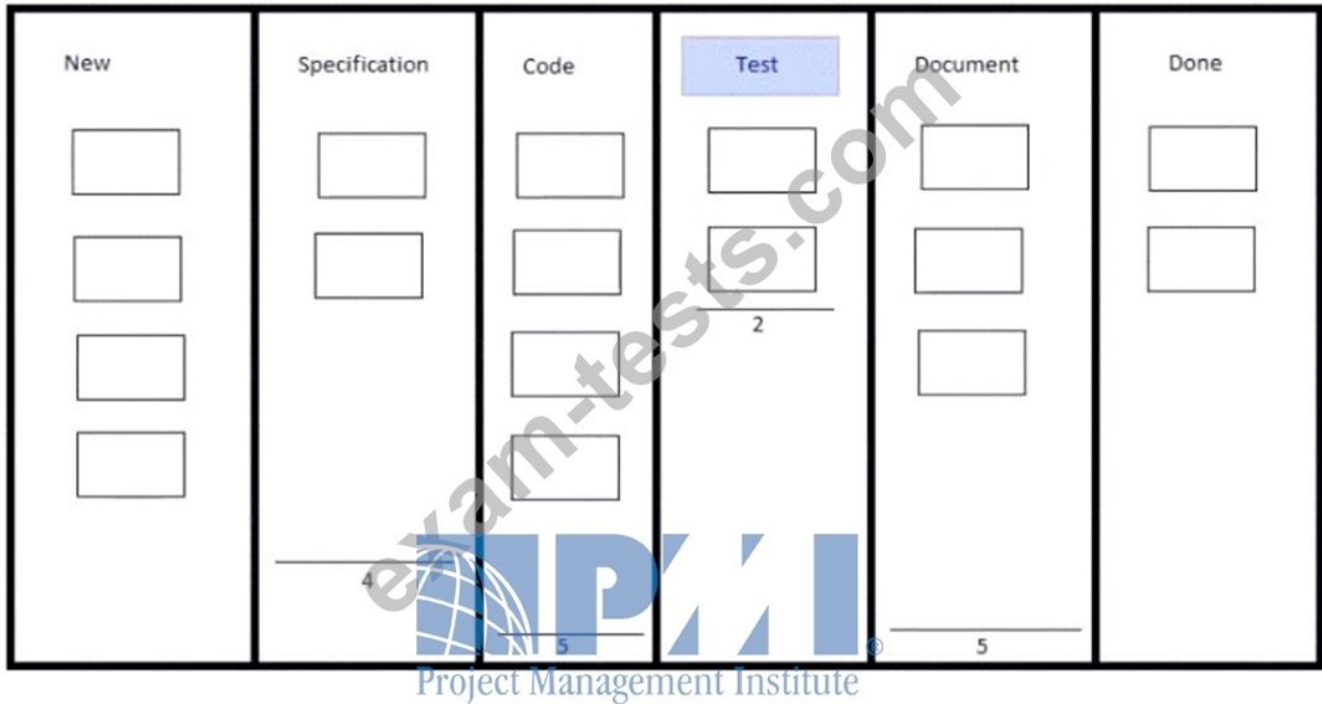

NEW QUESTION: 261

The definitive terms of a contract are written during which of the following contract phases?

- A. Pre-Award Phase
- B. Requirement Phase
- C. Contract Phase
- D. Post-Award Phase
- E. Award Phase

Answer: ([SHOW ANSWER](#))

NEW QUESTION: 262

During the execution of a project the project manager notices that only one team member has one of the technical skills needed to build the product. The project manager is afraid this might have a future impact on the quality and schedule because most of the upcoming activities will require at least three people with this specific skill.

What two actions should the project manager take to prevent the team from being unqualified?
(Choose two)

- A. Encourage working in pairs and knowledge sharing
- B. Increase the time estimates on the activities that require such abilities
- C. Teach the entire team the new skill.
- D. Exclude the activities from the roadmap
- E. Facilitate a training event with an external tracer

Answer: A,E ([LEAVE A REPLY](#))

NEW QUESTION: 263

During the execution of a project, a key stakeholder complains to the project manager about recent communications.

The key stakeholder explains that the relevant information from the project team was incomplete and late. As a result, the key stakeholder is beginning to disengage from the project.

What should the project manager do?

- A. Explain to the key stakeholder the way in which the project team communicates information.
- B. Send relevant information to all key stakeholders simultaneously to ensure consistent communication.
- C. Ask the project sponsor to hold a meeting with the key stakeholder to ensure that the stakeholder is engaged in the project.
- D. Update the communications management plan to fulfill the key stakeholder's expectations about relevant information.

Answer: ([SHOW ANSWER](#))

NEW QUESTION: 264

Which is a tool or technique used in scope definition?

- A. Templates, forms, and standards
- B. Change requests
- C. Stakeholder analysis
- D. Project assumptions

Answer: ([SHOW ANSWER](#))

Section: Initiation

NEW QUESTION: 265

A project sponsor asks to terminate a software installation project that is 80 percent complete. What should the project manager do first?

- A. Follow the project management plan to close the project.
- B. Meet with the sponsor to discuss the possibility of continuing the project.
- C. Release the project team to other projects.
- D. Proceed to complete the installation, then close the project.

Answer: ([SHOW ANSWER](#))

Section: Closing

NEW QUESTION: 266

A project is six months into project execution when a key stakeholder leaves the company and another person from the same functional area is assigned to the project. The project manager updates all project documentation with this information.

What should the project manager do before the next stakeholder's project review meeting?

- A. Send all of the project documents to the new stakeholder.
- B. Meet with the new stakeholder to introduce themselves and the team.
- C. Bring the new stakeholder up to date on any unresolved problems in project.

D. Determine if the planned communications will meet the new stakeholder's needs.

Answer: B ([LEAVE A REPLY](#))

Section: Executing

NEW QUESTION: 267

A project manager for a government organization often deals with stakeholder engagement issues. Drag the interpersonal skill the project manager should use on the left to the correct situation on the right.

The initial interface shows a list of interpersonal skills on the left and four situations on the right. The skills are: Decision making, Negotiation, Political awareness, and Cultural awareness. The situations are: 1. Site workers often come up with complaints about working conditions, but the project manager cannot improve the conditions. 2. The project manager wants to stay updated on instability in the government and the possibility that the current government leader may resign. 3. The project manager is assigned to work in a rural area where people have different customs. 4. A new government has been formed, and the project manager has been awarded a chair position to reform government policies.

Answer:

The final interface shows the correct matching of skills to situations. The skills on the left are: Decision making, Negotiation, Political awareness, and Cultural awareness. The situations on the right are: Negotiation, Political awareness, Cultural awareness, and Decision making. The correct matches are: Decision making to Site workers, Negotiation to Government instability, Political awareness to Rural area, and Cultural awareness to New government.

Explanation



NEW QUESTION: 268

A company has assigned a project manager to the initial task of determining the resources required for a new project. What should the project manager consult?

- A. Company's resource management plan
- B. Company's resource calendars
- C. Company's project responsibility assignment matrix (RAM)
- D. Company's historical organizational project artifacts

Answer: A (LEAVE A REPLY)

NEW QUESTION: 269

Which is developing an approximation of the costs of the resources needed to complete project activities.

- A. Determine Budget
- B. Resource planning
- C. Control Costs
- D. Estimate Costs

Answer: D (LEAVE A REPLY)

Estimate Costs: Assessing how much it will cost the organization to provide the product or service

NEW QUESTION: 270

You have summarized the project and note that 28,000 hours have been scheduled, 25,000 hours have been earned and 26,000 hours paid. The correct conclusion is:

- A. The project is operating at a favorable cost efficiency ratio.
- B. the project is spending more than planned
- C. the project is behind schedule
- D. the project is ahead of schedule
- E. B and C

Answer: C (LEAVE A REPLY)

Section: (none)

Explanation/Reference:

Here, $EV=25$, $PV=28$ and $AC=26$; so $CV = -1$, $SV = -3$ and $CPI = 0.96$ and $SPI = 0.89$. Therefore it is over budget and behind schedule; but over-budget by very insignificant point, while it is certainly behind schedule by over 10%. That's why answer is C.

NEW QUESTION: 271

You want to minimize the impact of changes on your project, yet you want to ensure that change is managed when and if it occurs. This can be done through each of the following ways EXCEPT _____.

- A. Rejecting requested changes
- B. Approving changes and incorporating them into a revised baseline
- C. Documenting the complete impact of requested changes
- D. Ensuring that project scope changes are reflected in changes to product scope

Answer: D (LEAVE A REPLY)

Section: Mix Questions

Explanation:

Integrated change control requires maintaining the integrity of baselines by releasing only approved changes into project products, services, or results. It also ensures that changes to product scope are reflected in the project scope definition. This is done by coordinating changes across the entire project.

Valid PMP Dumps shared by BraindumpsPass.com for Helping Passing PMP Exam! BraindumpsPass.com now offer the **newest PMP exam dumps**, the BraindumpsPass.com PMP exam **questions have been updated** and **answers have been corrected** get the **newest** BraindumpsPass.com PMP dumps with Test Engine here: <https://www.braindumpsPass.com/PMI/PMP-practice-exam-dumps.html> (1440 Q&As Dumps, **40%OFF Special Discount: Exam-Tests**)

NEW QUESTION: 272

A project manager has outsourced a critical programming task to a third party due to a lack of resources.

During the implementation stage, the deliverable is behind schedule and this task must be completed before a critical deadline.

What is the first thing the project manager should do to make sure the project gets back on track?

- A. Review the procurement documentation with the contractor to identify the alternatives
- B. Inform the major stakeholders and request that they work to identify a solution
- C. Search for a new outsourcing company as a replacement for the existing vendor

D. Discuss the option to support the supplier with internal resources with the project sponsor

Answer: D ([LEAVE A REPLY](#))

Section: Executing

NEW QUESTION: 273

You are in the process of reviewing offers and choosing among potential sellers. All of the following are tools you can use except:

- A. methods of preparing own independent estimates of costs
- B. methods to review seller progress to date
- C. methods to clarify the structure and requirements of the contracts
- D. methods to evaluate sellers on past performance and contractual compliance
- E. methods for establishing minimum requirements for performance of one or more evaluation criteria when selecting a prospective seller

Answer: B ([LEAVE A REPLY](#))

NEW QUESTION: 274

A recently appointed project manager is in constant conflict with a senior manager. Since this is not ideal for the team, the project manager wants to resolve this.

What should the project manager do?

- A. Enlist the help of a neutral mediator
- B. Escalate the issue to the project sponsor
- C. Request scheduled face-to-face meetings with the senior manager
- D. Seek guidance from other project managers

Answer: C ([LEAVE A REPLY](#))

NEW QUESTION: 275

Management reserves are normally defined as a % of the total budget. As a project progresses, the project manager wants the \$ value of management reserve to _____, whereas the customer wants the management reserve to _____.

- A. Increase, decrease.
- B. Increase, increase.
- C. Decrease, increase.
- D. Remain the same, return to customer.
- E. Decrease, decrease.

Answer: ([SHOW ANSWER](#))

NEW QUESTION: 276

A risk may be graded into different priorities by which process?

- A. Risk monitoring and controlling
- B. Quantitative risk analysis
- C. Qualitative risk analysis

D. Risk response planning

Answer: ([SHOW ANSWER](#))

Valid PMP Dumps shared by BraindumpsPass.com for Helping Passing PMP Exam!
BraindumpsPass.com now offer the **newest PMP exam dumps**, the BraindumpsPass.com
PMP exam **questions have been updated** and **answers have been corrected** get the
newest BraindumpsPass.com PMP dumps with Test Engine here:
<https://www.braindumpsPass.com/PMI/PMP-practice-exam-dumps.html> (**1440** Q&As Dumps,
40%OFF Special Discount: **Exam-Tests**)